

# INVT Electric

Каталог продукції для  
керування



## Company profile

---

Shenzhen INVT Electric Co., Ltd. (INVT for short, stock code: 002334) was founded in 2002, focusing on the fields of industrial automation and energy power. It was listed on Shenzhen Stock Exchange (SZSE) and issued A shares in 2010. Adhering to the core values of "Achieve customers, performance orientation, open and win-win cooperation, struggle and innovation" and with the mission of making every effort to offer most valuable products and services to strengthen customer competitiveness, INVT provides differentiated and specialized industry solutions, customized technical services, global localization operations, and digital management models to global customers.

### Core competitiveness

**Company scale:** INVT has 4 large bases of production and research, 15 holding subsidiaries, and over 5000 employees.

**R&D capability:** INVT is a national key high-tech enterprise in China's Torch Program and a drafting unit for the national standard of low-voltage VFDs. It has established a strict quality management system and passed CNAS certification. The R&D testing laboratory has been awarded the Acceptance of Client Testing (ACT) accreditation by TUV-SUD in Germany, and the main products are CE-compliant. INVT has also been recognized as the National Enterprise Technology Center, and Guangdong Engineering Technology Research Center, and has undertaken a number of national, provincial and municipal science and technology projects. By the end of 2023, INVT has 1538 patents and 283 computer software copyrights.

**Marketing and service network:** INVT has set up dozens of branches and hundreds of joint warranty centers around the world, and has established strong cooperative relationships with many domestic and international channel partners. This comprehensive sales and service network enables INVT to respond quickly to global market demands and provide immediate technical support and quality after-sales service.

### Business segments

**Industrial automation:** Offering VFDs, servo systems, motors, controllers, human-machine interfaces, sensors, elevator drive systems, industrial internet, and other products and integrated solutions, which are widely used in compressors, cranes, solar pumps, printing and packaging machinery, 3C electronics, lithium-ion battery equipment, semiconductor equipment, offshore equipment, iron and steel, petroleum, chemical industry, and other fields.

**Network power:** Offering micro module data centers, power supply and distribution products, intelligent temperature control products, intelligent monitoring products, and integrated solutions, which are widely used in cloud data centers, finance, communication, medical, energy, and other fields.

**New energy vehicle:** Offering comprehensive products such as main motor controllers, auxiliary motor controllers, vehicle controllers, and onboard power supplies, covering the full range of solutions for commercial vehicles and passenger cars.

**PV energy storage:** Offering grid-tie inverters, energy storage inverters, off-grid inverters, monitoring accessories, which have been applied in many scenarios at home and abroad.

# CONTENT



**P3**

**Small PLC**

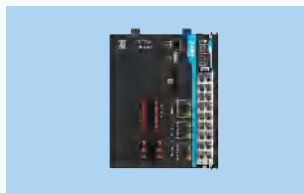

**P27**

**Medium PLC**



**P37**

**X86 Controller**



**P43**

**I/O system**



**P65**

**HMI**

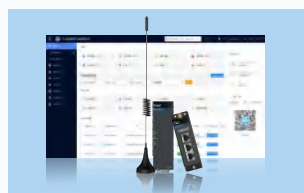

**P73**

**Industrial internet**

# INVT Automation networking

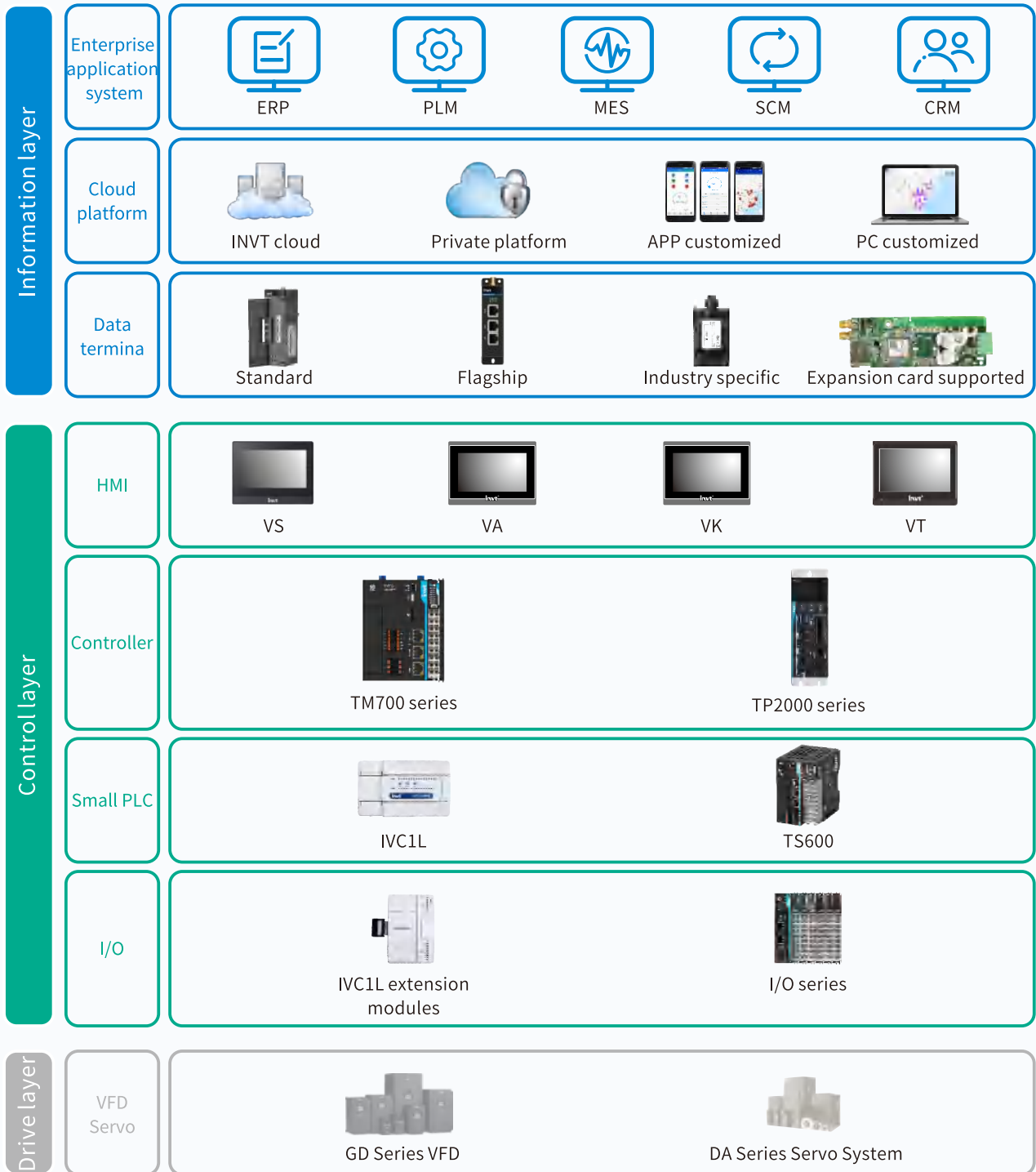

# Small PLC

IVC series PLC features fast speed, stable performance, strong function and software usability.



## IVC1L feature

IVC1L is a general-purpose PLC product with compact structure, complete functions, and flexible I/O configuration. It can be widely used in small-scale IO and simple positioning applications.

- 60 built-in I/O points, able to add on 7 modules and 128 I/O points
- 16K steps program capacity
- 1 RS232, 2 RS485, supporting the Modbus master/slave protocol
- Two 50K+four 10K high speed input ports
- Three 100K high speed output (transistor type) ports
- Support real time clock function and built-in battery
- Support DC power supply and AC power supply modules



## IVC1L technical specification

| Model                                 | IVC1L-           | 0806MAT  | 1410MAT | 1614MAT | 1614MAT1   | 2416MAT | 3624MAT | 0806MAR                                 | 1410MAR | 1614MAR | 2416MAR | 3624MAR |  |
|---------------------------------------|------------------|--|---------|---------|------------|---------|---------|---|---------|---------|---------|---------|--|
| <b>Power</b>                          |                  |  |         |         |            |         |         |   |         |         |         |         |  |
| Input                                 | Voltage          | 220VAC (85~264VAC)   |         |         |            |         |         |   |         |         |         |         |  |
|                                       | Current          | 1.5A   |         |         |            |         |         |   |         |         |         |         |  |
| Output                                | 5V/GND           | 900mA  |         |         |            |         |         |   |         |         |         |         |  |
|                                       | 24V/GND          | 300mA  |         |         |            |         |         |   |         |         |         |         |  |
|                                       | 24V/COM          | 600mA  |         |         |            |         |         |   |         |         |         |         |  |
| <b>I/O configuration</b>              |                  |  |         |         |            |         |         |   |         |         |         |         |  |
| Built-in I/O                          | Total            | 14   | 24      | 30      | 30         | 40      | 60      | 14                                      | 24      | 30      | 40      | 60      |  |
|                                       | Input            | 8  | 14      | 16      | 16         | 24      | 36      | 8                                       | 14      | 16      | 24      | 36      |  |
|                                       | Output           | 6  | 10      | 14      | 14         | 16      | 24      | 6                                       | 10      | 14      | 16      | 24      |  |
|                                       | Input type       | NPN/PNP  |         |         |            |         |         | NPN/PNP                                 |         |         |         |         |  |
|                                       | Output type      | Transistor (NPN)   |         |         |            |         |         | Relay                                   |         |         |         |         |  |
| Extension I/O                         | Extension module | 7  |         |         |            |         |         |   |         |         |         |         |  |
|                                       | Total            | 128  |         |         |            |         |         |   |         |         |         |         |  |
| Analog                                |                  | -  |         |         | 2 AI, 1 AO |         | -       |   |         |         |         |         |  |
| <b>High speed I/O</b>                 |                  |  |         |         |            |         |         |   |         |         |         |         |  |
| High speed input                      |                  | 2×50KHz+4×10KHz, AB phase (1×30K, 1×5K)  |         |         |            |         |         | 2×50KHz+4×10KHz, AB phase (1×30K, 1×5K) |         |         |         |         |  |
| High speed output                     |                  | 3×100KHz   |         |         |            |         |         | -                                       |         |         |         |         |  |
| <b>Communication</b>                  |                  |  |         |         |            |         |         |   |         |         |         |         |  |
| Serial port                           | RS232            | 1  |         |         |            |         |         |   |         |         |         |         |  |
|                                       | RS485            | 2  |         |         |            |         |         |   |         |         |         |         |  |
|                                       | Protocol         | Programming protocol; MODBUS master/slave; free port; N:N protocol                                       |         |         |            |         |         |   |         |         |         |         |  |
| <b>Storage</b>                        |                  |  |         |         |            |         |         |   |         |         |         |         |  |
| Program capacity                      |                  | 16K steps  |         |         |            |         |         |   |         |         |         |         |  |
| Data block                            |                  | 8000 D registers   |         |         |            |         |         |   |         |         |         |         |  |
| <b>Interrupt</b>                      |                  |  |         |         |            |         |         |   |         |         |         |         |  |
| External input interrupt              |                  | 16   |         |         |            |         |         |   |         |         |         |         |  |
| High speed counter interrupt          |                  | 6  |         |         |            |         |         |   |         |         |         |         |  |
| Internal time interrupt               |                  | 3  |         |         |            |         |         |   |         |         |         |         |  |
| Serial port interrupt                 |                  | 12   |         |         |            |         |         |   |         |         |         |         |  |
| PTO output completion interrupt       |                  | 3  |         |         |            |         |         |   |         |         |         |         |  |
| Power loss interrupt                  |                  | 1  |         |         |            |         |         |   |         |         |         |         |  |
| <b>Programming</b>                    |                  |  |         |         |            |         |         |   |         |         |         |         |  |
| Software                              |                  | Auto Station   |         |         |            |         |         |   |         |         |         |         |  |
| Subprogram calling                    |                  | Supported total 64 subprograms (6 levels), and it can supports the design of input and output interfaces |         |         |            |         |         |   |         |         |         |         |  |
| <b>Others</b>                         |                  |  |         |         |            |         |         |   |         |         |         |         |  |
| Digital filtering function            |                  | X0-X7 adopts digital filtering and other ports adopt hardware filtering                                  |         |         |            |         |         |   |         |         |         |         |  |
| Encryption                            |                  | Upload/download password, monitor password, subprogram encryption, format disable, upload disable        |         |         |            |         |         |   |         |         |         |         |  |
| Real time clock                       |                  | Support, built-in battery  |         |         |            |         |         |   |         |         |         |         |  |
| Data saving function at power failure |                  | Supported  |         |         |            |         |         |   |         |         |         |         |  |

| Model                                 | IVC1L-   | 0806MDT  | 1410MDT | 1614MDT | 2416MDT | 3624MDT | 0806MDR | 1410MDR | 1614MDR                                 | 2416MDR | 3624MDR    | 1614MAR1           | 1616MAR6             |  |
|---------------------------------------|--|--|---------|---------|---------|---------|---------|---------|---|---------|------------|--------------------|----------------------|--|
| <b>Power</b>                          |  |  |         |         |         |         |         |         |   |         |            |                    |                      |  |
| Input                                 | Voltage  | 24VDC (19~30VDC)   |         |         |         |         |         |         |   |         |            | 220VAC (85~264VAC) |                      |  |
|                                       | Current  | 0.85A  |         |         |         |         |         |         |   |         |            | 15A                |                      |  |
| Output                                | 5V/GND   | 900mA  |         |         |         |         |         |         |   |         |            |                    |                      |  |
|                                       | 24V/GND  | 300mA  |         |         |         |         |         |         |   |         |            |                    |                      |  |
|                                       | 24V/COM  | -  |         |         |         |         |         |         |   |         |            | 600mA              |                      |  |
| <b>I/O configuration</b>              |  |  |         |         |         |         |         |         |   |         |            |                    |                      |  |
| Built-in I/O                          | Total  | 14   | 24      | 30      | 40      | 60      | 14      | 24      | 30                                      | 40      | 60         | 30                 | 32                   |  |
|                                       | Input  | 8  | 14      | 16      | 24      | 36      | 8       | 14      | 16                                      | 24      | 36         | 16                 | 16                   |  |
|                                       | Output   | 6  | 10      | 14      | 16      | 24      | 6       | 10      | 14                                      | 16      | 24         | 14                 | 16                   |  |
|                                       | Input type   | NPN/PNP  |         |         |         |         |         | NPN/PNP |   |         |            |                    |                      |  |
|                                       | Output type  | Transistor (NPN)   |         |         |         |         |         | Relay   |   |         |            |                    |                      |  |
| Extension I/O                         | Extension module   | 7  |         |         |         |         |         |         |   |         |            |                    |                      |  |
|                                       | Total  | 128  |         |         |         |         |         |         |   |         |            |                    |                      |  |
| Analog                                | -  |  |         |         |         |         |         |         |   |         | 2 AI, 1 AO |                    | 2 thermal resistance |  |
| <b>High speed I/O</b>                 |  |  |         |         |         |         |         |         |   |         |            |                    |                      |  |
| High speed input                      | 2×50KHz+4×10KHz, AB phase (1×30K, 1×5K)  |  |         |         |         |         |         |         | 2×50KHz+4×10KHz, AB phase (1×30K, 1×5K) |         |            |                    |                      |  |
| High speed output                     | 3×100KHz   |  |         |         |         |         |         |         | -                                       |         |            |                    |                      |  |
| <b>Communication</b>                  |  |  |         |         |         |         |         |         |   |         |            |                    |                      |  |
| Serial port                           | RS232  | 1  |         |         |         |         |         |         |   |         |            |                    |                      |  |
|                                       | RS485  | 2  |         |         |         |         |         |         |   |         |            |                    |                      |  |
|                                       | Protocol   | Programming protocol; MODBUS master/slave; free port; N:N protocol |         |         |         |         |         |         |   |         |            |                    |                      |  |
| <b>Storage</b>                        |  |  |         |         |         |         |         |         |   |         |            |                    |                      |  |
| Program capacity                      | 16K steps  |  |         |         |         |         |         |         |   |         |            |                    |                      |  |
| Data block                            | 8000 D registers   |  |         |         |         |         |         |         |   |         |            |                    |                      |  |
| <b>Interrupt</b>                      |  |  |         |         |         |         |         |         |   |         |            |                    |                      |  |
| External input interrupt              | 16   |  |         |         |         |         |         |         |   |         |            |                    |                      |  |
| High speed counter interrupt          | 6  |  |         |         |         |         |         |         |   |         |            |                    |                      |  |
| Internal time interrupt               | 3  |  |         |         |         |         |         |         |   |         |            |                    |                      |  |
| Serial port interrupt                 | 12   |  |         |         |         |         |         |         |   |         |            |                    |                      |  |
| PTO output completion interrupt       | 3  |  |         |         |         |         |         |         |   |         |            |                    |                      |  |
| Power loss interrupt                  | 1  |  |         |         |         |         |         |         |   |         |            |                    |                      |  |
| <b>Programming</b>                    |  |  |         |         |         |         |         |         |   |         |            |                    |                      |  |
| Software                              | Auto Station   |  |         |         |         |         |         |         |   |         |            |                    |                      |  |
| Subprogram calling                    | Supported total 64 subprograms (6 levels), and it can supports the design of input and output interfaces |  |         |         |         |         |         |         |   |         |            |                    |                      |  |
| <b>Others</b>                         |  |  |         |         |         |         |         |         |   |         |            |                    |                      |  |
| Digital filtering function            | X0~X7 adopts digital filtering and other ports adopt hardware filtering                                  |  |         |         |         |         |         |         |   |         |            |                    |                      |  |
| Encryption                            | Upload/download password, monitor password, subprogram encryption, format disable, upload disable        |  |         |         |         |         |         |         |   |         |            |                    |                      |  |
| Real time clock                       | Support, built-in battery  |  |         |         |         |         |         |         |   |         |            |                    |                      |  |
| Data saving function at power failure | Supported  |  |         |         |         |         |         |         |   |         |            |                    |                      |  |
| <b>IVC1L</b>                          |  |  |         |         |         |         |         |         |   |         |            |                    |                      |  |
| <b>Soft element</b>                   |  |  |         |         |         |         |         |         |   |         |            |                    |                      |  |
| Inputs                                | X element, 128   |  |         |         |         |         |         |         |   |         |            |                    |                      |  |
| Outputs                               | Y element, 128   |  |         |         |         |         |         |         |   |         |            |                    |                      |  |
| Auxiliary relays                      | M element, 2048  |  |         |         |         |         |         |         |   |         |            |                    |                      |  |
| Local auxiliary relays                | LM element, 64   |  |         |         |         |         |         |         |   |         |            |                    |                      |  |
| Special auxiliary relays              | SM element, 512  |  |         |         |         |         |         |         |   |         |            |                    |                      |  |
| Status relays                         | S element, 1024  |  |         |         |         |         |         |         |   |         |            |                    |                      |  |
| Data registers                        | D element, 8000  |  |         |         |         |         |         |         |   |         |            |                    |                      |  |
| Local data registers                  | V element, 64  |  |         |         |         |         |         |         |   |         |            |                    |                      |  |
| Indexing/addressing registers         | Z element, 16  |  |         |         |         |         |         |         |   |         |            |                    |                      |  |
| Special data registers                | SD element, 512  |  |         |         |         |         |         |         |   |         |            |                    |                      |  |
| Timer                                 | Total  | T element, 256   |         |         |         |         |         |         |   |         |            |                    |                      |  |
|                                       | 1ms  | T252~T255  |         |         |         |         |         |         |   |         |            |                    |                      |  |
|                                       | 10ms   | T210~T251  |         |         |         |         |         |         |   |         |            |                    |                      |  |
|                                       | 100ms  | T0~T209  |         |         |         |         |         |         |   |         |            |                    |                      |  |
| Counter                               | Total  | C element, 256   |         |         |         |         |         |         |   |         |            |                    |                      |  |
|                                       | 16bit up counter   | C0~C199  |         |         |         |         |         |         |   |         |            |                    |                      |  |
|                                       | 32bit up/down counter  | C200~C235  |         |         |         |         |         |         |   |         |            |                    |                      |  |
|                                       | 32bit high speed counter   | C236~C255  |         |         |         |         |         |         |   |         |            |                    |                      |  |
| Rising edge                           | 1024   |  |         |         |         |         |         |         |   |         |            |                    |                      |  |
| Falling edge                          | 1024   |  |         |         |         |         |         |         |   |         |            |                    |                      |  |

## IVC1L dimension

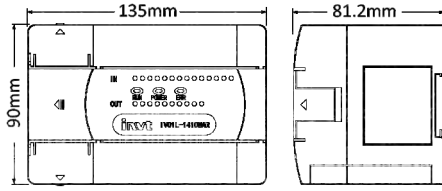

| Model                          | Dimension     |
|--------------------------------|---------------|
| IVC1L-0806M**<br>IVC1L-1410M** | 135×90×81.2mm |

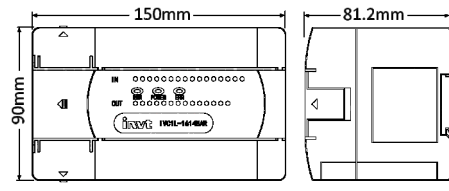

| Model         | Dimension     |
|---------------|---------------|
| IVC1L-1614M** | 150×90×81.2mm |

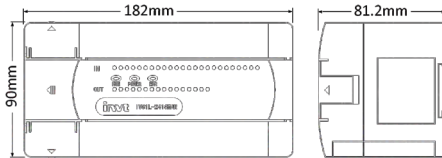

| Model   | Dimension     |
|---|---------------|
| IVC1L-1614MAR1<br>IVC1L-1614MAT1<br>IVC1L-1616MAR6<br>IVC1L-2416M** | 182×90×81.2mm |

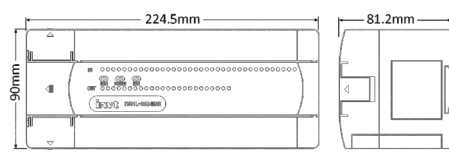

| Model         | Dimension       |
|---------------|-----------------|
| IVC1L-3624M** | 224.5×90×81.2mm |

## IVC1L(AC) wiring diagram

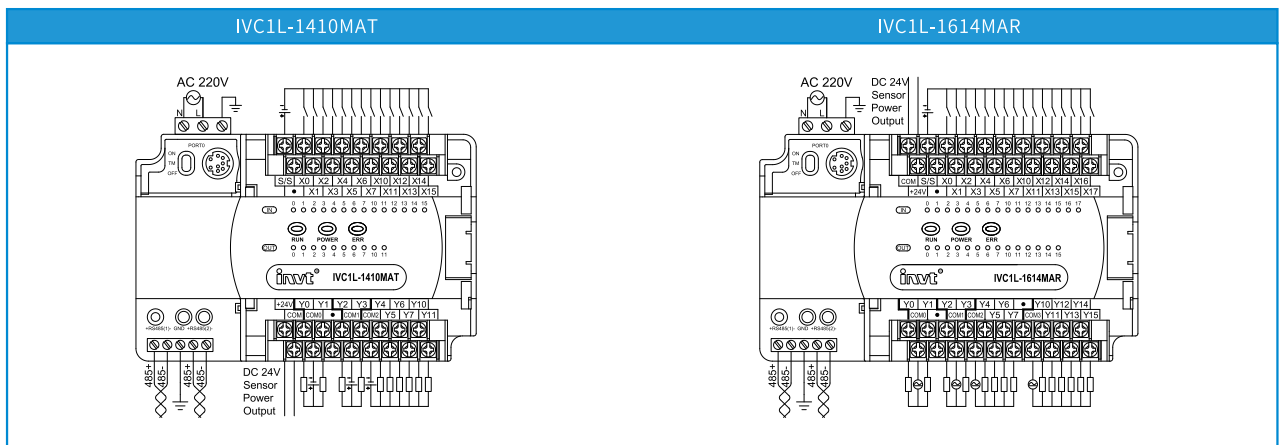
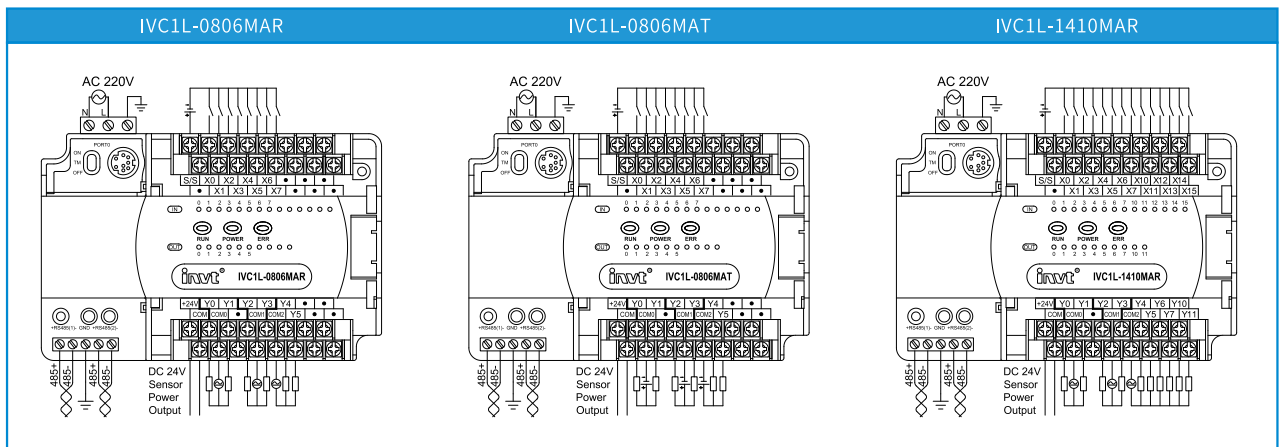

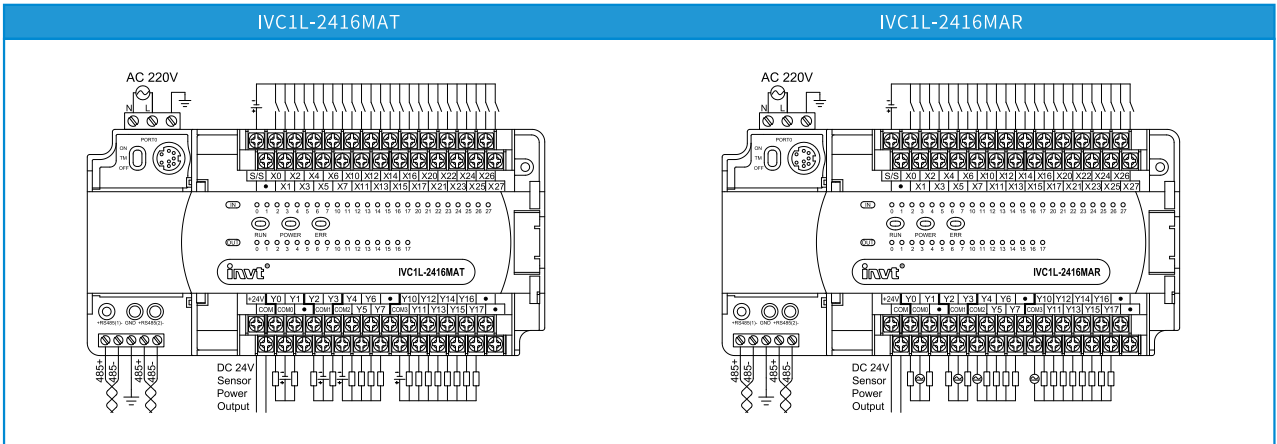
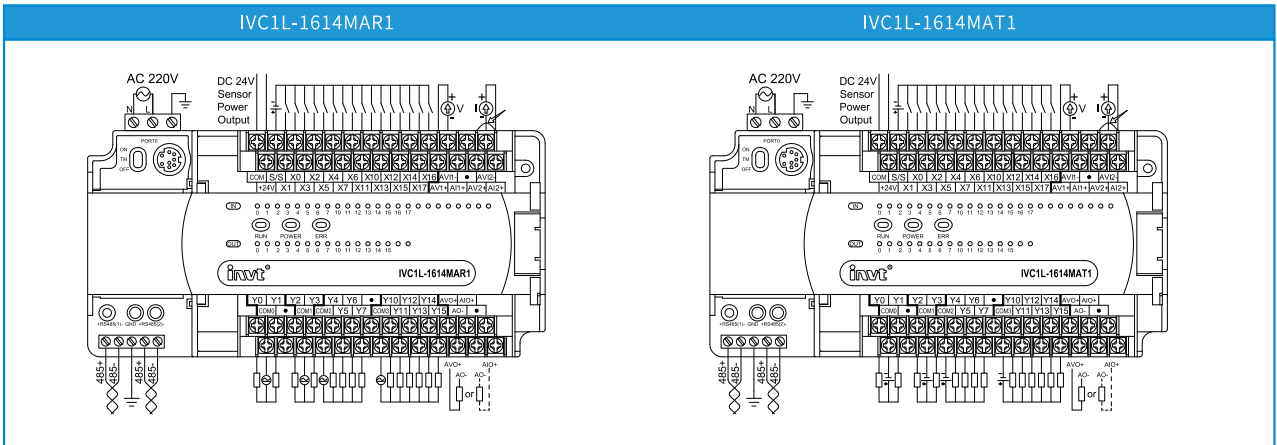
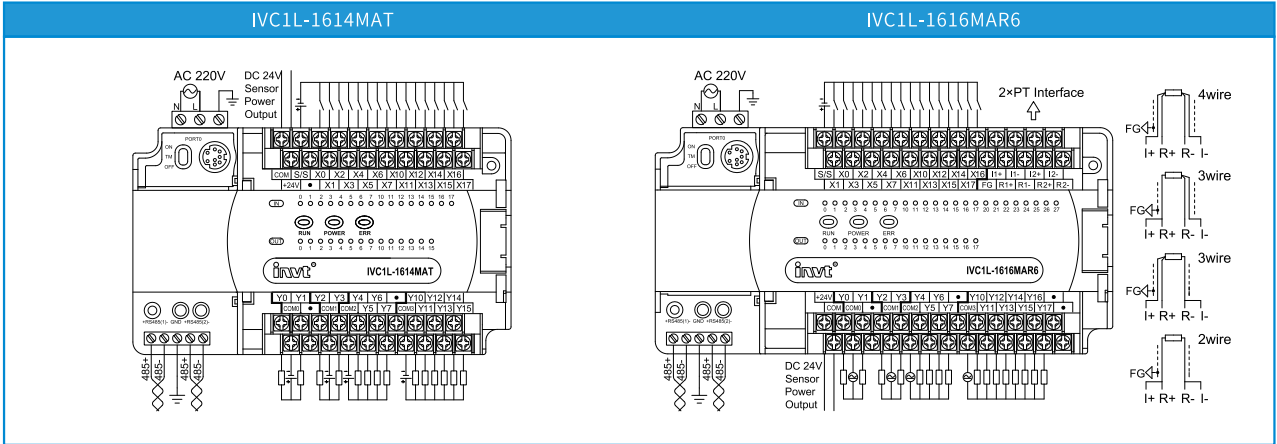

IVC1L-3624MAT

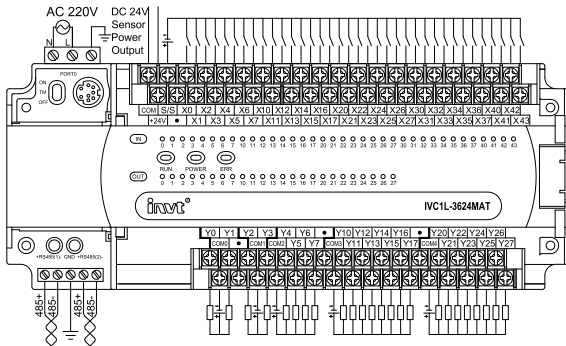

IVC1L-3624MAR

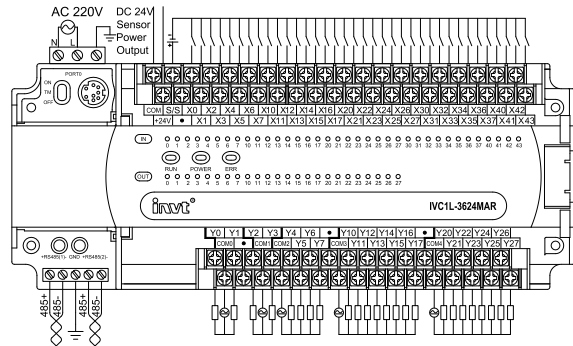

IVC1L(DC) wiring diagram

IVC1L-0806MDR

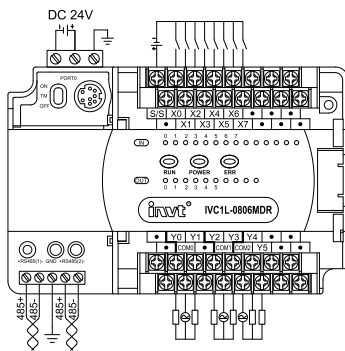

IVC1L-0806MDT

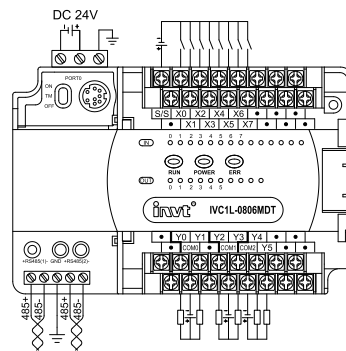

IVC1L-1410MDR

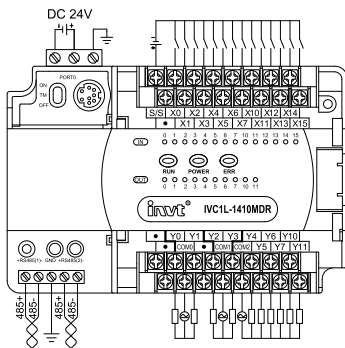

IVC1L-1410MDT

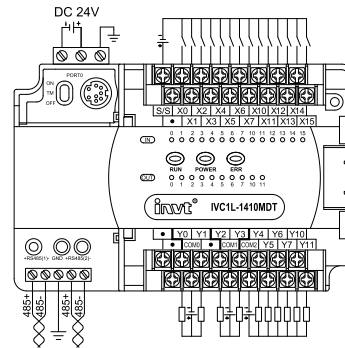

IVC1L-1614MDR

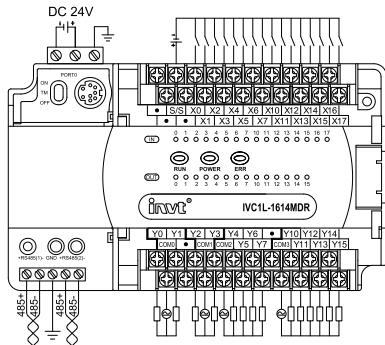

IVC1L-1614MDT

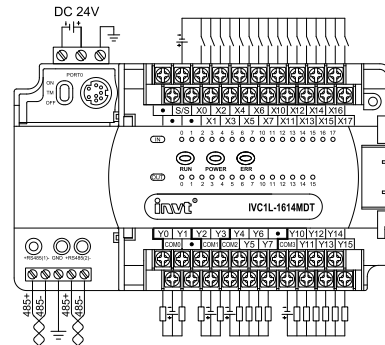

IVC1L-2416MDR

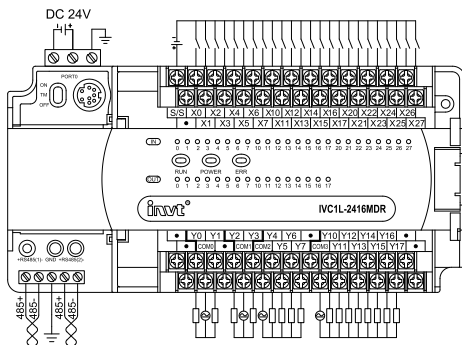

IVC1L-2416MDT

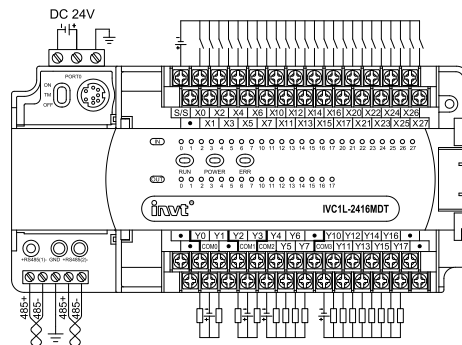

IVC1L-3624MDR

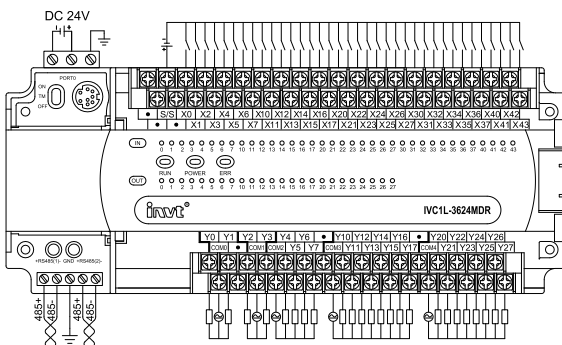

IVC1L-3624MDT

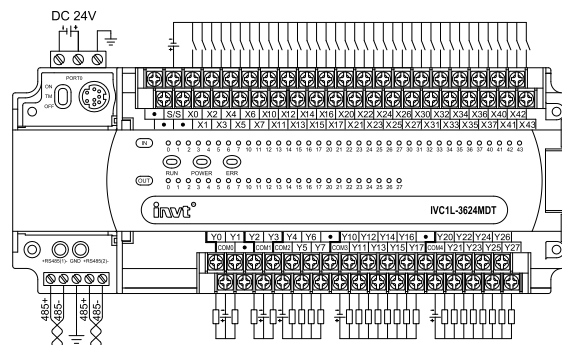

● Digital input module



| Model                 |         | IVC1L-1600ENN                        |
|-----------------------|---------|--------------------------------------|
| Product overview      |         | 16 digital inputs                    |
| General               |         |                                      |
| Dimension             |         | 61×90×81.2mm                         |
| Power                 | 5V/GND  | 70mA                                 |
|                       | 24V/GND | —                                    |
| Output specification  |         |                                      |
| Inputs                |         | 16                                   |
| Input type            |         | PNP/NPN (source type/sink type)      |
| Input voltage         |         | 24VDC                                |
| Current               |         | 60mA (DC24V/COM)                     |
| Insulation            |         | Optocoupler insulation               |
| Action indication     |         | LED is on when optocoupler is driven |
| Equivalent resistance |         | 4.3kΩ/channel                        |
| Logic 1 signal        |         | ≥15VDC                               |
| Logic 0 signal        |         | ≤5VDC                                |

● Digital output module



| Model                |                | IVC1L-0016ENT  |
|----------------------|----------------|--|
| Product overview     |                | 16 points transistor output  |
| General              |                |  |
| Dimension            |                | 61×90×81.2mm   |
| Power                | 5V/GND         | 170mA  |
|                      | 24V/GND        | —  |
| Output specification |                |  |
| Outputs              |                | 16   |
| Output type          |                | Transistor   |
| Voltage              |                | 24VDC  |
| Insulation           |                | Optocoupler insulation   |
| Action indication    |                | LED is on when optocoupler is driven   |
| Minimum load         |                | 5mA (5~24VDC)  |
| Max. output current  | Resistive load | Total current can be increased by 0.1A for every additional 1 point above 8 points |
|                      | Inductive load | 24VDC, 7.2W  |
|                      | Lamp load      | 24VDC, 1.5W  |
| Response time        | OFF→ON         | Max.0.5ms (100mA/24VDC)  |
|                      | ON→OFF         | Max.0.5ms (100mA/24VDC)  |
| Contact life         |                | —  |



| Model                |                | IVC1L-0016ENR   |
|----------------------|----------------|---|
| Product overview     |                | 16 points relay output  |
| General              |                |   |
| Dimension            |                | 61×90×81.2mm  |
| Power                | 5V/GND         | 70mA  |
|                      | 24V/GND        | 100mA   |
| Output specification |                |   |
| Outputs              |                | 16  |
| Output type          |                | Relay   |
| Voltage              |                | 250VAC, below 30VDC   |
| Insulation           |                | Mechanical insulation of relay  |
| Action indication    |                | The LED light is on when relay output contact closed                            |
| Minimum load         |                | 2mA/5VDC  |
| Max. output current  | Resistive load | 2A/1point, The total current of 8 points of common COM terminal is less than 8A |
|                      | Inductive load | 220VAC, 80VA  |
|                      | Lamp load      | 220VAC, 100W  |
| Response time        | OFF→ON         | Max.20ms  |
|                      | ON→OFF         | Max.20ms  |
| Contact life         |                | 200,000 time  |

• Digital input/output module



| Model                       |                | IVC1L-0808ENT                                |
|-----------------------------|----------------|--|
| Product overview            |                | 8 digital inputs, 8 points transistor output |
| <b>General</b>              |                |  |
| Dimension                   |                | 61×90×81.2mm                                 |
| Power                       | 5V/GND         | 170mA  |
|                             | 24V/GND        | -  |
| <b>Input specification</b>  |                |  |
| Inputs                      |                | 8  |
| Input type                  |                | PNP/NPN (source type/sink type)              |
| Input voltage               |                | 24VDC  |
| Current                     |                | 50mA (DC24V/COM)                             |
| Insulation                  |                | Optocoupler insulation                       |
| Action indication           |                | LED is on when optocoupler is driven         |
| Equivalent resistance       |                | 4.3kΩ/channel                                |
| Logic 1 signal              |                | ≥15VDC                                       |
| Logic 0 signal              |                | ≤5VDC  |
| <b>Output specification</b> |                |  |
| Outputs                     |                | 8  |
| Output type                 |                | Transistor                                   |
| Voltage                     |                | 5-24VDC                                      |
| Insulation                  |                | Optocoupler insulation                       |
| Action indication           |                | LED is on when optocoupler is driven         |
| Minimum load                |                | 5mA (5-24VDC)                                |
| Max. output current         | Resistive load | 0.3A/1 point 0.8A/4points 1.6A/8points       |
|                             | Inductive load | 24VDC, 7.2W                                  |
|                             | Lamp load      | 24VDC, 1.5W                                  |
| Response time               | OFF→ON         | Max.0.5ms (100mA/24VDC)                      |
|                             | ON→OFF         | Max.0.5ms (100mA/24VDC)                      |
| Contact life                |                | -  |



| Model                       |                | IVC1L-0808ENR  |
|-----------------------------|----------------|--|
| Product overview            |                | 8 digital inputs,8 points relay output   |
| <b>General</b>              |                |  |
| Dimension                   |                | 61×90×81.2mm   |
| Power                       | 5V/GND         | 70mA   |
|                             | 24V/GND        | 50mA   |
| <b>Input specification</b>  |                |  |
| Inputs                      |                | 8  |
| Input type                  |                | PNP/NPN (source type/sink type)  |
| Input voltage               |                | 24VDC  |
| Current                     |                | 50mA (DC24V/COM)   |
| Insulation                  |                | Optocoupler insulation   |
| Action indication           |                | LED is on when optocoupler is driven   |
| Equivalent resistance       |                | 4.3kΩ/channel  |
| Logic 1 signal              |                | ≥15VDC   |
| Logic 0 signal              |                | ≤5VDC  |
| <b>Output specification</b> |                |  |
| Outputs                     |                | 8  |
| Output type                 |                | Relay  |
| Voltage                     |                | 250VAC, below 30VDC  |
| Insulation                  |                | Mechanical insulation of relay   |
| Action indication           |                | The LED light is on when relay output contact closed                             |
| Minimum load                |                | 2mA/5VDC   |
| Max. output current         | Resistive load | 2A/1point , The total current of 8 points of common COM terminal is less than 8A |
|                             | Inductive load | 220VAC, 80VA   |
|                             | Lamp load      | 220VAC, 100W   |
| Response time               | OFF→ON         | Max.20ms   |
|                             | ON→OFF         | Max.20ms   |
| Contact life                |                | 200,000 time   |

Small PLC

Medium PLC

X86 Controller

I/O System

HMI

Industrial Internet

● Analog input module



| Model                      | IVC1L-2AD  |                   |
|----------------------------|--|-------------------|
| Product overview           | 2 analog inputs  |                   |
| <b>General</b>             |  |                   |
| Dimension                  | 61×90×81.2mm   |                   |
| Power                      | 5V/GND   | 70mA              |
|                            | 24V/GND  | -                 |
| <b>Input specification</b> |  |                   |
| Conversion speed           | 15ms/channel (normal speed), 6ms/channel (high speed), settable  |                   |
| Range                      | Voltage input  | -10V~+10V -5V~+5V |
|                            | Current input  | -20mA~+20mA       |
| Digital format             | Default: -2000~+2000; Range: -10000~+10000   |                   |
| Resolution                 | 12 bit   |                   |
| Accuracy                   | ±1%FS  |                   |
| Isolation                  | The optocoupler isolates analog circuit from digital circuit. The analog circuit is internally isolated from the 24VDC power supply of the module. No isolation between analog channels. |                   |

| Model                      | IVC1L-4AD  |                   |
|----------------------------|--|-------------------|
| Product overview           | 4 analog inputs  |                   |
| <b>General</b>             |  |                   |
| Dimension                  | 61×90×81.2mm   |                   |
| Power                      | 5V/GND   | 70mA              |
|                            | 24V/GND  | -                 |
| <b>Input specification</b> |  |                   |
| Conversion speed           | 15ms/channel (normal speed), 6ms/channel (high speed), settable  |                   |
| Range                      | Voltage input  | -10V~+10V -5V~+5V |
|                            | Current input  | -20mA~+20mA       |
| Digital format             | Default: -2000~+2000; Range: -10000~+10000   |                   |
| Resolution                 | 12 bit   |                   |
| Accuracy                   | ±1%FS  |                   |
| Isolation                  | The optocoupler isolates analog circuit from digital circuit. The analog circuit is internally isolated from the 24VDC power supply of the module. No isolation between analog channels. |                   |

● Analog output module



| Model                       | IVC1L-2DA  |               |
|-----------------------------|--|---------------|
| Product overview            | 2 analog outputs   |               |
| <b>General</b>              |  |               |
| Dimension                   | 61×90×81.2mm   |               |
| Power                       | 5V/GND   | 72mA          |
|                             | 24V/GND  | -             |
| External power              | 24VDC (-15%~20%), Maximum allowable ripple voltage 5%,100mA  |               |
| <b>Output specification</b> |  |               |
| Conversion speed            | 2ms/channel  |               |
| Range                       | Voltage output   | -10V~+10V     |
|                             | Current output   | 0~20mA 4~20mA |
| Digital format              | Default: -2000~+2000; Range: -10000~+10000   |               |
| Resolution                  | 12 bit   |               |
| Accuracy                    | ±1%FS  |               |
| Isolation                   | The optocoupler isolates analog circuit from digital circuit. The analog circuit is internally isolated from the 24VDC power supply of the module. No isolation between analog channels. |               |

| Model                       | IVC1L-4DA  |               |
|-----------------------------|--|---------------|
| Product overview            | 4 analog outputs   |               |
| <b>General</b>              |  |               |
| Dimension                   | 61×90×81.2mm   |               |
| Power                       | 5V/GND   | 72mA          |
|                             | 24V/GND  | -             |
| External power              | 24VDC (-15%~20%), Maximum allowable ripple voltage 5%, 100mA   |               |
| <b>Output specification</b> |  |               |
| Conversion speed            | 2ms/channel  |               |
| Range                       | Voltage output   | -10V~+10V     |
|                             | Current output   | 0~20mA 4~20mA |
| Digital format              | Default: -2000~+2000; Range: -10000~+10000   |               |
| Resolution                  | 12 bit   |               |
| Accuracy                    | ±1%FS  |               |
| Isolation                   | The optocoupler isolates analog circuit from digital circuit. The analog circuit is internally isolated from the 24VDC power supply of the module. No isolation between analog channels. |               |

## ● Analog input/output module



| Model                |                | IVC1L-5AM  |  |
|----------------------|----------------|--|--|
| Product overview     |                | 4 analog inputs, 1 analog output   |  |
| General              |                |  |  |
| Dimension            |                | 61×90×81.2mm   |  |
| Power                | 5V/GND         | 72mA   |  |
|                      | 24V/GND        | -  |  |
| Input specification  |                |  |  |
| Conversion speed     |                | 15ms/channel (normal speed), 8ms/channel (high speed), settable  |  |
| Voltage input        |                | -10V~+10V -5V~+5V  |  |
| Range                | Current input  | -20mA~+20mA  |  |
|                      | Digital format | Default: -2000~+2000; Range: -10000~+10000   |  |
| Resolution           |                | 12 bit   |  |
| Accuracy             |                | ±1%FS  |  |
| Isolation            |                | The optocoupler isolates analog circuit from digital circuit. The analog circuit is internally isolated from the 24VDC power supply of the module. No isolation between analog channels. |  |
| Output specification |                |  |  |
| Conversion speed     |                | 2ms/channel  |  |
| Voltage output       |                | -10V~+10V  |  |
| Range                | Current output | 0~20mA 4~20mA  |  |
|                      | Digital format | Default: -2000~+2000; Range: -10000~+10000   |  |
| Resolution           |                | 12 bit   |  |
| Accuracy             |                | ±1%FS  |  |
| Isolation            |                | The optocoupler isolates analog circuit from digital circuit. The analog circuit is internally isolated from the 24VDC power supply of the module. No isolation between analog channels. |  |

## ● Thermocouple module



| Model               |                      | IVC1L-4TC  |   |
|---------------------|----------------------|--|---|
| Product overview    |                      | 4 thermocouple   |   |
| General             |                      |  |   |
| Dimension           |                      | 61×90×81.2mm   |   |
| Power               | 5V/GND               | 72mA   |   |
|                     | 24V/GND              | -  |   |
| External power      |                      | 24VDC (-15%~20%), Maximum allowable ripple voltage5%, 50mA   |   |
| Input specification |                      |  |   |
| Conversion speed    |                      | 240ms/channel  |   |
| Input type          |                      | K/J/E/N/T/R/S type thermocouple  |   |
| Digital format      | Celsius (0.1 ° C)    | K type: -1000~+12000<br>E type: -1000~+10000<br>T type: -2000~+4000<br>S type: 0~16000   | J type: -1000~+10000<br>N type: -1000~+12000<br>R type: 0~16000   |
|                     | Fahrenheit (0.1 ° F) | K type: -1480~+21920<br>E type: -1480~+18320<br>T type: -3280~+7520<br>S type: 320~29120   | J type: -1480~+18320<br>N type: -1480~+21920<br>R type: 320~29120 |
| Resolution          |                      | 0.5 ° C/0.9 ° F; 12bit   |   |
| Accuracy            |                      | ±0.5%FS+1 ° C  |   |
| Isolation           |                      | The optocoupler isolates analog circuit from digital circuit. The analog circuit is internally isolated from the 24VDC power supply of the module. No isolation between analog channels. |   |



| Model               |                      | IVC1L-2TC  |   |
|---------------------|----------------------|--|---|
| Product overview    |                      | 2 thermocouple   |   |
| General             |                      |  |   |
| Dimension           |                      | 61×90×81.2mm   |   |
| Power               | 5V/GND               | 72mA   |   |
|                     | 24V/GND              | -  |   |
| External power      |                      | 24VDC (-15%~20%), Maximum allowable ripple voltage5%, 50mA   |   |
| Input specification |                      |  |   |
| Conversion speed    |                      | 240ms/channel  |   |
| Input type          |                      | K/J/E/N/T/R/S type thermocouple  |   |
| Digital format      | Celsius (0.1 ° C)    | K type: -1000~+12000<br>E type: -1000~+10000<br>T type: -2000~+4000<br>S type: 0~16000   | J type: -1000~+10000<br>N type: -1000~+12000<br>R type: 0~16000   |
|                     | Fahrenheit (0.1 ° F) | K type: -1480~+21920<br>E type: -1480~+18320<br>T type: -3280~+7520<br>S type: 320~29120   | J type: -1480~+18320<br>N type: -1480~+21920<br>R type: 320~29120 |
| Resolution          |                      | 0.5 ° C/0.9 ° F; 12bit   |   |
| Accuracy            |                      | ±0.5%FS+1 ° C  |   |
| Isolation           |                      | The optocoupler isolates analog circuit from digital circuit. The analog circuit is internally isolated from the 24VDC power supply of the module. No isolation between analog channels. |   |

● Thermal resistance module



| Model                      |                      | IVC1L-2PT  |
|----------------------------|----------------------|--|
| Product overview           |                      | 2 thermal resistance   |
| <b>General</b>             |                      |  |
| Dimension                  |                      | 61×90×81.2mm   |
| Power                      | 5V/GND               | 72mA   |
|                            | 24V/GND              | —  |
| External power             |                      | 24VDC (-15%~20%), Maximum allowable ripple voltage5%, 50mA   |
| <b>Input specification</b> |                      |  |
| Conversion speed           |                      | 15ms/channel   |
| Input type                 |                      | Pt100/Cu100/Cu50   |
| Digital format             | Celsius (0.1 ° C)    | Pt100: -1500~+6000<br>Cu100: -300~+1200<br>Cu50: -300~+1200  |
|                            | Fahrenheit (0.1 ° F) | Pt100: -2380~+11120<br>Cu100: -220~+2480<br>Cu50: -220~+2480   |
| Resolution                 |                      | 0.2 ° C/0.36 ° F; 12bit  |
| Accuracy                   |                      | ±1%FS  |
| Isolation                  |                      | The optocoupler isolates analog circuit from digital circuit.<br>The analog circuit is internally isolated from the 24VDC power supply of the module.<br>No isolation between analog channels. |

| Model                      |                      | IVC1L-4PT  |
|----------------------------|----------------------|--|
| Product overview           |                      | 4 thermal resistance   |
| <b>General</b>             |                      |  |
| Dimension                  |                      | 61×90×81.2mm   |
| Power                      | 5V/GND               | 72mA   |
|                            | 24V/GND              | —  |
| External power             |                      | 24VDC (-15%~20%), Maximum allowable ripple voltage5%, 50mA   |
| <b>Input specification</b> |                      |  |
| Conversion speed           |                      | 15ms/channel   |
| Input type                 |                      | Pt100/Cu100/Cu50   |
| Digital format             | Celsius (0.1 ° C)    | Pt100: -1500~+6000<br>Cu100: -300~+1200<br>Cu50: -300~+1200  |
|                            | Fahrenheit (0.1 ° F) | Pt100: -2380~+11120<br>Cu100: -220~+2480<br>Cu50: -220~+2480   |
| Resolution                 |                      | 0.2 ° C/0.36 ° F; 12bit  |
| Accuracy                   |                      | ±1%FS  |
| Isolation                  |                      | The optocoupler isolates analog circuit from digital circuit.<br>The analog circuit is internally isolated from the 24VDC power supply of the module.<br>No isolation between analog channels. |

IVC1L extension module dimension

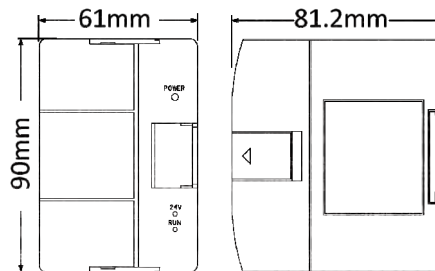

| Model                  | Dimension    |
|------------------------|--------------|
| IVC1L extension module | 61×90×81.2mm |

# IVC1L extension module wiring diagram

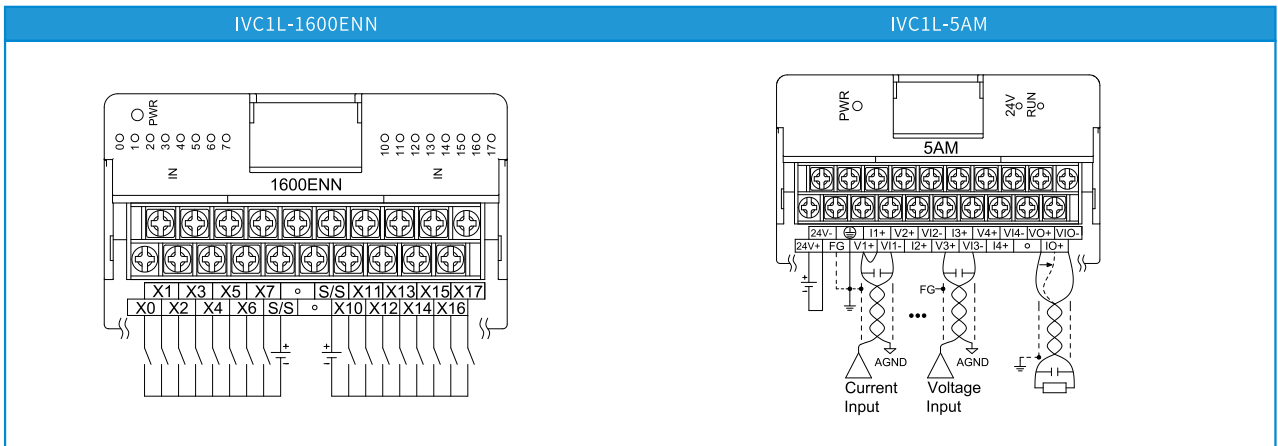
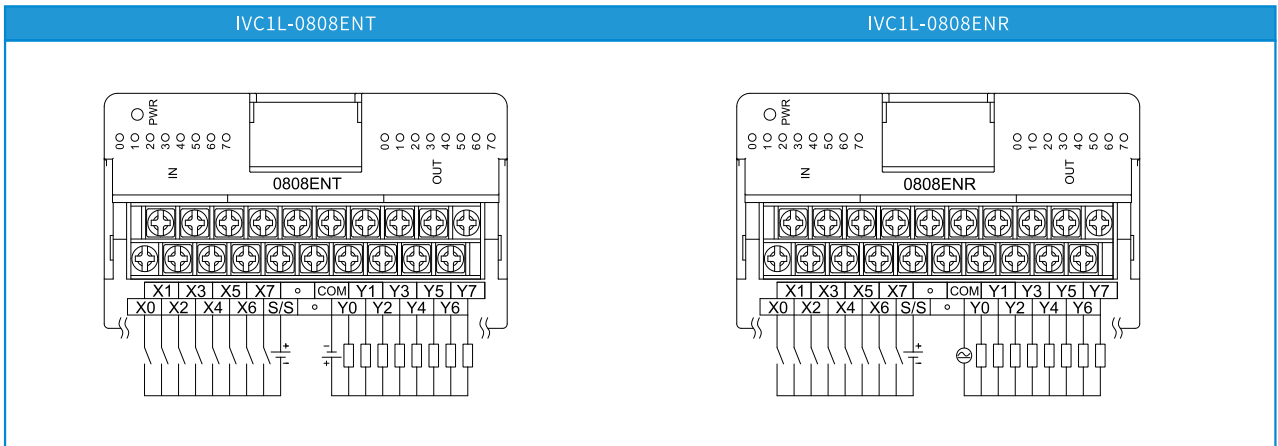
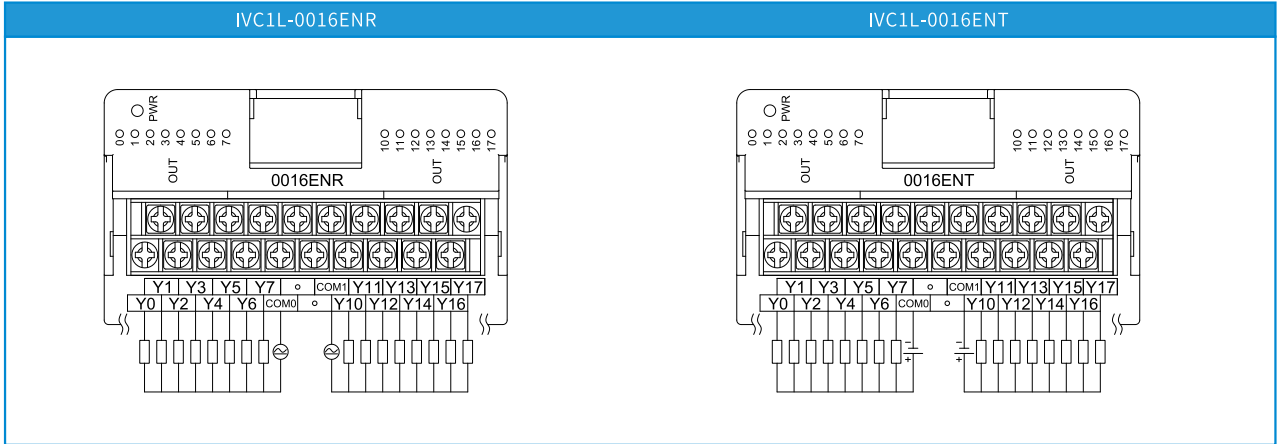

Small PLC  
Medium PLC  
X86 Controller  
I/O System  
HMI  
Industrial Internet

IVC1L-2AD

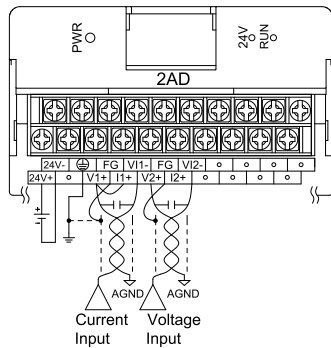

IVC1L-4AD

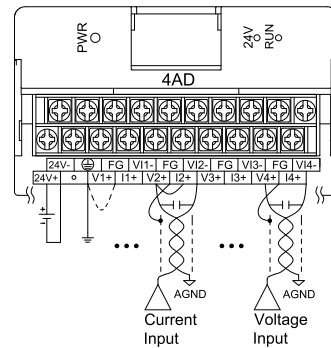

IVC1L-2DA

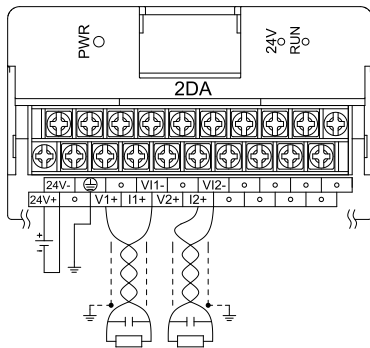

IVC1L-4DA

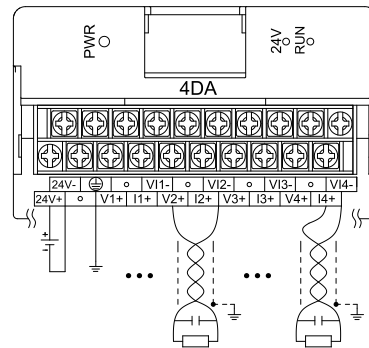

IVC1L-2PT/IVC1L-4PT

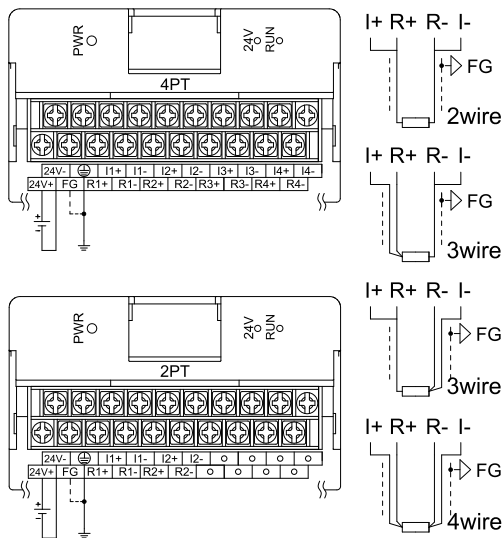

IVC1L-2TC/IVC1L-4TC

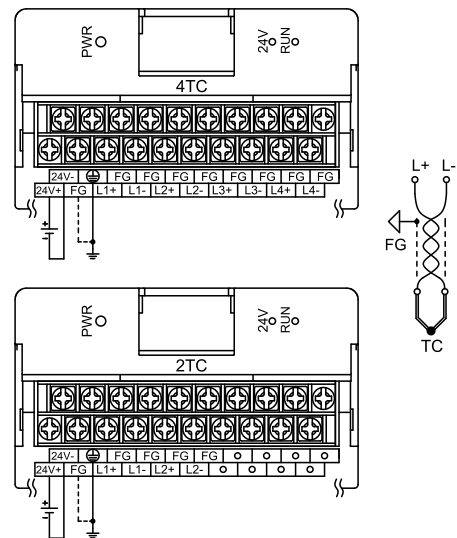

## IVC PLC spare part

| Product type | Description                            | Photo |
|--------------|--|-------|
| IVC-SL1      | PLC-VS HMI 232 communication cable(2m) |       |

| Product type | Description                                  | Photo |
|--------------|--|-------|
| IVC-SL5      | PLC-VT/VK/VA HMI 232 communication cable(7m) |       |

| Product type | Description                               | Photo |
|--------------|---|-------|
| IVC-SL2      | PLC download cable, USB-RS232(Port0) (2m) |       |

| Product type | Description                            | Photo |
|--------------|--|-------|
| IVC-SL8      | PLC-VS HMI 232 communication cable(7m) |       |

| Product type | Description                                  | Photo |
|--------------|--|-------|
| IVC-SL3      | PLC-VT/VK/VA HMI 232 communication cable(3m) |       |

| Product type | Description               | Photo |
|--------------|---------------------------|-------|
| IVC-SL9      | IVC1L extension cable(1m) |       |

| Product type | Description  | Photo |
|--------------|--|-------|
| IVC-SL4      | HMI download cable, available for VT/VK/VA/VS series(2m) |       |

## TS600 Series Intelligent PLC

INVT TS600 series intelligent PLC integrates high-performance embedding technology, and it is based on a high-speed bus system architecture to integrate four types of automation control, namely, sequence, process, information, and motion control, into the same system. It achieves the real-time control and complex calculation through the highly reliable software and hardware real-time system, and provides open communication interfaces, IoT networks, and distributed module system architecture. The completely independent programming software provides customized services, making programming easy.

TS600 can work with INVT VFD, servo, HMI, IoT and other products to construct one-stop automation solutions to create value for customers.



### Product positioning



Product positioning

Running efficiently

1G main frequency, compile command breakthrough, bit operation speeding up to 0.01μs

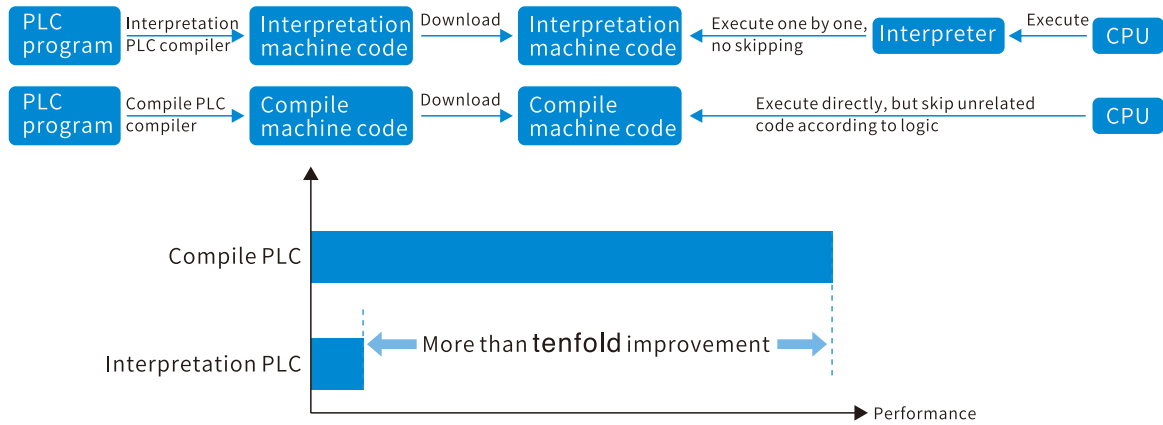

100Mbps backplane bus; 125μs IO refresh speed; plating process, reliable connection; saving data at power down, 1s power-down ride-through



Product positioning

High-speed motion control, easily implementing complex processes

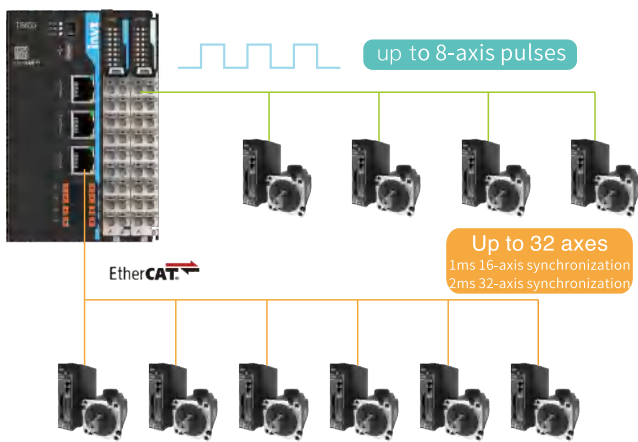

|                          |                    |               |
|--------------------------|--------------------|---------------|
| Single-axis control      | Multi-axis control | Flying shear  |
| speed and torque control | E-gear             |               |
| Position control         | E-CAM              | Chasing shear |
| Homing                   | Interpolation      |               |

Small PLC  
Medium PLC  
X86 Controller  
I/O System  
HMI  
Industrial Internet

## Easy connection

### Multi-protocol support facilitates interconnection

- ▣ Dual-port design, makes cascading easy, and achieves the isolation between the internal network and external network

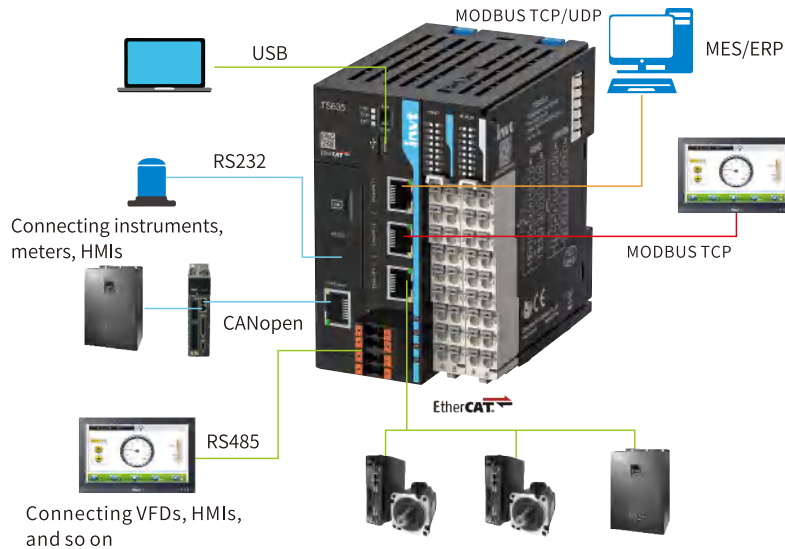

\* Ethernet IP master/slave nodes supported

## Easy programming

- ▣ Equipped with the brand new AutoStationPro

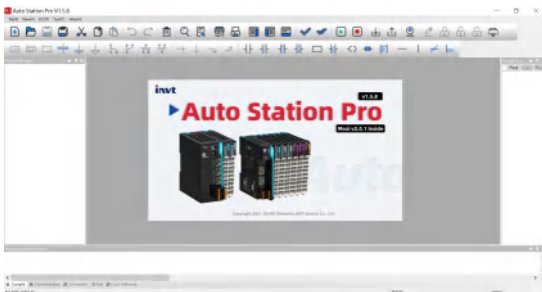

- ▣ Supporting user-defined variables

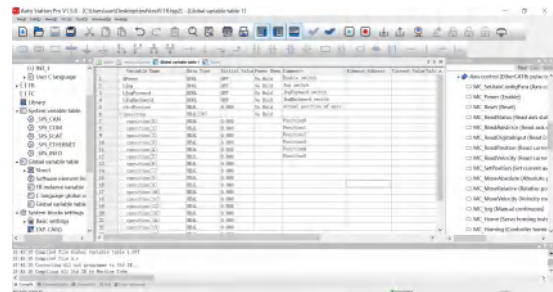

- ▣ Compliant with IEC61131 programming specifications, supporting the languages LD, SFC, IL, C, and ST (under development). The pulse and bus axes are compatible with a set of axis control commands.

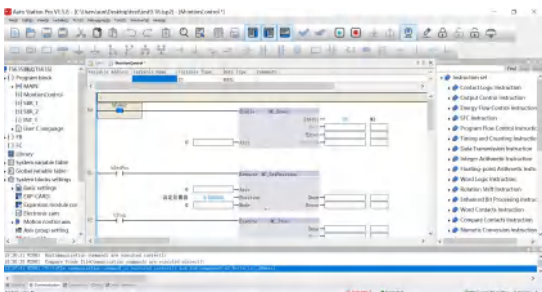

- ▣ Supporting graphic configuration through dragging, Easy parameter setup and automatic address allocation

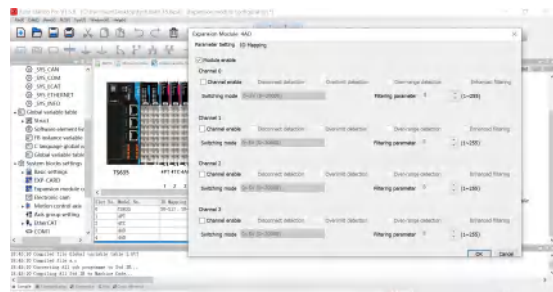

### Trace function

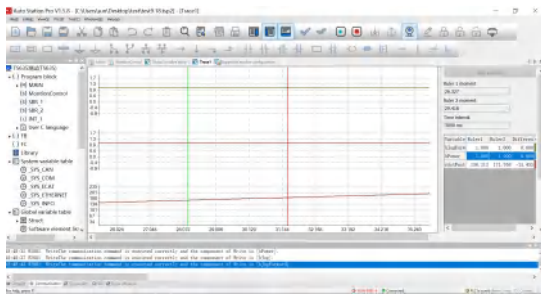

## Easy scalability

### Standard configuration of CPU

- 8/16 points of DI
- 8 200kHz high-speed inputs
- 8/16 points of DO
- 8/16 200kHz high speed outputs

### Compatible with Flex series I/O modules for scaling

Up to 16 I/O modules can be expanded locally  
 Use of push-in terminals, facilitating wiring  
 Vertical plug-in assembly, with working time reduced by 80%  
 Mounting space reduced by more than 60%, compared with traditional modules

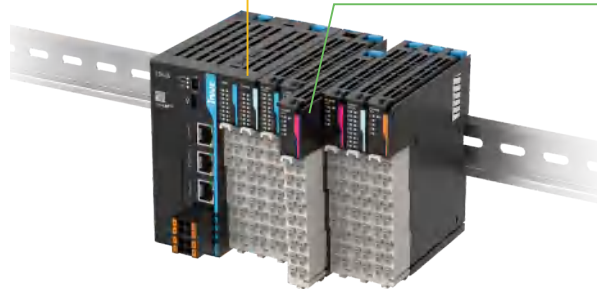

\*TS620 and TS630 are equipped with 8 digital inputs and 8 digital outputs.  
 TS611, TS621, and TS621P support 16 channels of 200kHz high-speed output.

### Supporting various expansion cards

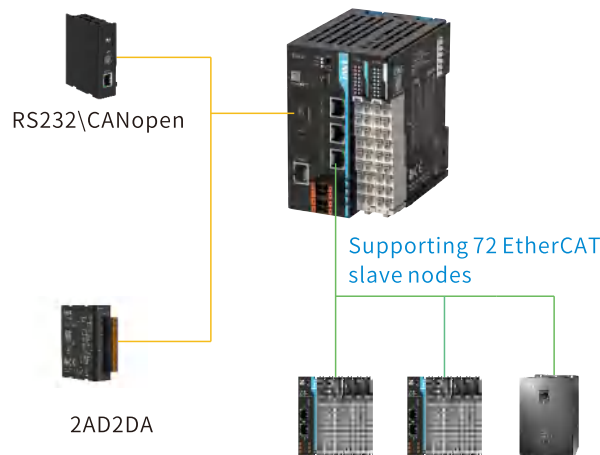

## Product specifications



| Model                               | TS635   | TS634               | TS634P              | TS633              | TS633P             | TS630   | TS621  | TS621P  | TS620   | TS620R   | TS611        |  |
|-------------------------------------|---|---------------------|---------------------|--------------------|--------------------|---|--|---|---|--|--------------|--|
| <b>General specifications</b>       |   |                     |                     |                    |                    |   |  |   |   |  |              |  |
| EtherNet interface                  | 2   | 2                   | 2                   | 2                  | 2                  | 1   | 2  | 2   | 1   | 1  | -            |  |
| EtherCAT interface                  | 1   | 1                   | 1                   | 1                  | 1                  | 1   | -  | -   | -   | -  | -            |  |
| Max. number of axes (bus+pulse)     | 32 (bus) +4 (pulse)   | 16 (bus) +4 (pulse) | 16 (bus) +4 (pulse) | 8 (bus) +4 (pulse) | 8 (bus) +4 (pulse) | 8 (bus) +4 (pulse)  | 8 (pulse)  | 8 (pulse)   | 4 (pulse)   | -  | 8 (pulse)    |  |
| RS485 bus                           | 2 channels, supporting Modbus RTU master/slave function   |                     |                     |                    |                    |   |  |   |   |  |              |  |
| EtherNet bus                        | Supporting Modbus TCP/UDP, program upload and download, and firmware upgrade  |                     |                     |                    |                    |   |  |   |   |  | -            |  |
| USB interface                       | 1 channel, Type-C interface, supporting program upload and download, and firmware upgrade   |                     |                     |                    |                    |   |  |   |   |  |              |  |
| DI                                  | 16 inputs originally, including eight 200kHz high-speed inputs  |                     |                     |                    |                    | 8 inputs originally, including eight 200kHz high-speed inputs   | 16 inputs originally, including eight 200kHz high-speed inputs     | 8 inputs originally, including eight 200kHz high-speed inputs   | 8 inputs originally, including eight 200kHz high-speed inputs | 16 inputs originally, including eight 200kHz high-speed inputs     |              |  |
| DO                                  | 16 outputs originally, including eight 200kHz high-speed outputs  |                     |                     |                    |                    | 8 outputs originally, including eight 200kHz high-speed outputs | 16 outputs originally, including sixteen 200kHz high-speed outputs | 8 outputs originally, including eight 200kHz high-speed outputs | 6 outputs originally, Relay outputs                           | 16 outputs originally, including sixteen 200kHz high-speed outputs |              |  |
| Pulse axis                          | up to 4 axes  |                     |                     |                    |                    |   | up to 8 axes   |   | up to 4 axes  | -  | up to 8 axes |  |
| Input power                         | 24V DC (-15% – +20%)/1A, supporting reversal protection   |                     |                     |                    |                    |   |  |   |   |  |              |  |
| Standalone power consumption        | <3W   |                     |                     |                    |                    |   |  |   |   |  |              |  |
| Backplane bus power supply          | 5V/2.5A   |                     |                     |                    |                    |   |  |   |   |  |              |  |
| Power-down protection               | Supported (retention by the internal flash)   |                     |                     |                    |                    |   |  |   |   |  |              |  |
| Real-time clock                     | Supported (CR2032 battery is optional; the real-time clock works about four days without a battery)   |                     |                     |                    |                    |   |  |   |   |  |              |  |
| Local expansion modules             | Expand Flex series I/O, Up to 16, disallowing hot swapping  |                     |                     |                    |                    |   |  |   |   |  |              |  |
| Local expansion card                | 1 expansion card, supporting SD card, CANopen card, RS232 card and so on  |                     |                     |                    |                    |   |  |   |   |  |              |  |
| Program language                    | LD, SFC, IL, and C  |                     |                     |                    |                    |   |  |   |   |  |              |  |
| Program download                    | USB port, Ethernet port, SD card (expansion card), and remote download (expansion card)   |                     |                     |                    |                    |   |  |   |   |  |              |  |
| Program data capacity               | 200K steps of user program<br>2MByte user-defined variables, in which 128KByte support power-down retention<br>About 150K soft elements, the soft elements numbered after 1000 support power-down retention |                     |                     |                    |                    |   |  |   |   |  |              |  |
| Command speed (step)                | 20K steps at 0.2ms  |                     |                     |                    |                    |   |  |   |   |  |              |  |
| Bit handling command                | 0.0127μs  |                     |                     |                    |                    |   |  |   |   |  |              |  |
| Word transmission command           | 0.0014μs  |                     |                     |                    |                    |   |  |   |   |  |              |  |
| Floating-point transmission command | 0.0027μs  |                     |                     |                    |                    |   |  |   |   |  |              |  |
| Four operations of math             | 0.033μs   |                     |                     |                    |                    |   |  |   |   |  |              |  |
| <b>Power specifications</b>         |   |                     |                     |                    |                    |   |  |   |   |  |              |  |
| Terminal input power rated voltage  | 24V DC  |                     |                     |                    |                    |   |  |   |   |  |              |  |
| Terminal input power rated current  | 1A  |                     |                     |                    |                    |   |  |   |   |  |              |  |
| 24V input power protection          | Protection against reverse connection and surges  |                     |                     |                    |                    |   |  |   |   |  |              |  |
| Hot swapping of module              | Not supported   |                     |                     |                    |                    |   |  |   |   |  |              |  |

| Model                               | TS635   | TS634  | TS634P | TS633  | TS633P                          | TS630 | TS621   | TS621P | TS620                           | TS620R | TS611   |  |
|-------------------------------------|---|--------|--------|--------|---------------------------------|-------|---|--------|---------------------------------|--------|---|--|
| <b>Input specifications</b>         |   |        |        |        |                                 |       |   |        |                                 |        |   |  |
| Input type                          | digital input   |        |        |        |                                 |       |   |        |                                 |        |   |  |
| Number of input channels            | 16  |        |        |        | 8                               |       | 16  |        | 8                               |        | 16  |  |
| Input mode                          | Source and sink   |        |        |        |                                 |       |   |        |                                 |        |   |  |
| Input voltage class                 | 24VDC(-10%~+10%)  |        |        |        |                                 |       |   |        |                                 |        |   |  |
| Input current                       | Typical value for X0-X7: 13.5mA; Typical value for X10-X17: 4.2mA                         |        |        |        | Typical value for X0-X7: 17.5mA |       | Typical value for X0-X7: 13.5mA; Typical value for X10-X17: 4.2mA |        | Typical value for X0-X7: 17.5mA |        | Typical value for X0-X7: 13.5mA; Typical value for X10-X17: 4.2mA |  |
| Max. input frequency                | 200kHz for X0-X7; 200Hz for X10-X17   |        |        |        | 200kHz for X0-X7                |       | 200kHz for X0-X7; 200Hz for X10-X17                               |        | 200kHz for X0-X7                |        | 200kHz for X0-X7; 200Hz for X10-X17                               |  |
| Input resistance                    | Typical value for X0-X7: 1.7kΩ; Typical value for X10-X17: 5.7kΩ                          |        |        |        | Typical value for X0-X7: 1.3kΩ  |       | Typical value for X0-X7: 1.7kΩ; Typical value for X10-X17: 5.7kΩ  |        | Typical value for X0-X7: 1.3kΩ  |        | Typical value for X0-X7: 1.7kΩ; Typical value for X10-X17: 5.7kΩ  |  |
| ON voltage                          | ≥ 15VDC   |        |        |        |                                 |       |   |        |                                 |        |   |  |
| OFF voltage                         | ≤ 5VDC  |        |        |        |                                 |       |   |        |                                 |        |   |  |
| Isolation method                    | Capacitive isolation  |        |        |        |                                 |       |   |        |                                 |        |   |  |
| Common terminal method              | 8 channels/group  |        |        |        |                                 |       |   |        |                                 |        |   |  |
| Input action display                | When the input is in the driving state, the input indicator is on (software control)      |        |        |        |                                 |       |   |        |                                 |        |   |  |
| <b>Output specifications</b>        |   |        |        |        |                                 |       |   |        |                                 |        |   |  |
| Output type                         | Transistor output   |        |        |        |                                 |       |   |        |                                 |        |   |  |
| Number of output channels           | 16  |        |        |        | 8                               |       | 16  |        | 8                               |        | -   |  |
| Output mode                         | sink  | Source | sink   | Source | sink                            | sink  | Source  | sink   | -                               | -      | sink  |  |
| Output voltage class                | 24VDC(-10%~+10%)  |        |        |        |                                 |       |   |        |                                 |        |   |  |
| Output load (resistive)             | 0.5A/point, 2A/group  |        |        |        |                                 |       |   |        |                                 |        |   |  |
| output load (inductive)             | 7.2W/point, 24W/group   |        |        |        |                                 |       |   |        |                                 |        |   |  |
| Hardware response time              | <2us  |        |        |        |                                 |       |   |        |                                 |        |   |  |
| Load current requirement            | Load current ≥ 12mA when output frequency is greater than 10kHz                           |        |        |        |                                 |       |   |        |                                 |        |   |  |
| Max. output frequency               | 200kHz for resistive load, 0.5Hz for inductive load, and 10Hz for lighting load           |        |        |        |                                 |       |   |        |                                 |        |   |  |
| Leakage current at OFF              | Below 30μA (24V typical voltage)  |        |        |        |                                 |       |   |        |                                 |        |   |  |
| Max. residual voltage at ON         | ≤ 0.5VDC  |        |        |        |                                 |       |   |        |                                 |        |   |  |
| Isolation method                    | Optocoupler isolation   |        |        |        |                                 |       |   |        |                                 |        |   |  |
| Common terminal method              | 8 channels/group  |        |        |        |                                 |       |   |        |                                 |        |   |  |
| Short-circuit protection function   | Supported   |        |        |        |                                 |       |   |        |                                 |        |   |  |
| External inductive load requirement | Flyback diode needed for external inductive load connection                               |        |        |        |                                 |       |   |        |                                 |        |   |  |
| Output action display               | When the output is valid, the output indicator is on (software control)                   |        |        |        |                                 |       |   |        |                                 |        |   |  |
| Output derating                     | The current at each common terminal group cannot exceed 1A at ambient temperature of 55°C |        |        |        |                                 |       |   |        |                                 |        |   |  |
| <b>TS620R Output specifications</b> |   |        |        |        |                                 |       |   |        |                                 |        |   |  |
| Output type                         | Relay output  |        |        |        |                                 |       |   |        |                                 |        |   |  |
| Output mode                         | Dry node  |        |        |        |                                 |       |   |        |                                 |        |   |  |
| Number of output channels           | 6   |        |        |        |                                 |       |   |        |                                 |        |   |  |
| Output voltage class                | 250VAC/30VDC  |        |        |        |                                 |       |   |        |                                 |        |   |  |
| Maximum switching voltage           | 250VAC/125VDC (@0.3A)   |        |        |        |                                 |       |   |        |                                 |        |   |  |
| Output load (resistive load)        | 3A/point, 8A/module   |        |        |        |                                 |       |   |        |                                 |        |   |  |
| Output load (Inductive load)        | 1A/point, 4A/module   |        |        |        |                                 |       |   |        |                                 |        |   |  |
| Output load (lamp load)             | 30W/point, 120W/module  |        |        |        |                                 |       |   |        |                                 |        |   |  |
| contact resistance                  | <100mΩ (1A 6VDC)  |        |        |        |                                 |       |   |        |                                 |        |   |  |
| Minimum load                        | 5VDC 10mA   |        |        |        |                                 |       |   |        |                                 |        |   |  |
| Mechanical life                     | 20,000,000 times  |        |        |        |                                 |       |   |        |                                 |        |   |  |
| Electrical life                     | 100,000 times   |        |        |        |                                 |       |   |        |                                 |        |   |  |
| Isolation method                    | High voltage/Low voltage isolation  |        |        |        |                                 |       |   |        |                                 |        |   |  |

## Expansion card specifications



| Model                           | TS-CAN-232   |
|---------------------------------|--|
| Product description             | TS600 series expansion card, which supports Micro SD cards, CANopen bus, and one channel of RS232 communication                                      |
| IP rating                       | IP20   |
| Working temperature             | -20°C~55°C   |
| Terminal resistor               | Built-in terminal resistor, which can be selected through the dial switch  |
| RS232                           | 1  |
| CAN communication baud rate     | 1Mbps: Distance<20m<br>500Kbps: Distance<80m<br>250Kbps: Distance<150m<br>125Kbps: Distance<300m<br>100Kbps: Distance<500m<br>50Kbps: Distance<1000m |
| SD card capacity                | Up to 32GB   |
| SD card specifications          | Micro SD   |
| SD card communication interface | SDIO   |
| Hot swapping                    | Supported by SD cards, but not supported by the expansion card   |



| Model                           | EC-CAN   |
|---------------------------------|--|
| Product description             | TS/TM series expansion card, 2*RJ45, 1*MicroSD card (SD card only supports TS series)  |
| IP rating                       | IP20   |
| Working temperature             | -20°C~55°C   |
| Terminal resistor               | Built-in terminal resistor, which can be selected through the dial switch  |
| CAN communication baud rate     | 1Mbps: Distance<20m<br>500Kbps: Distance<80m<br>250Kbps: Distance<150m<br>125Kbps: Distance<300m<br>100Kbps: Distance<500m<br>50Kbps: Distance<1000m |
| SD card capacity                | Up to 32GB   |
| SD card specifications          | Micro SD   |
| SD card communication interface | SDIO   |
| Hot swapping                    | Supported by SD cards, but not supported by the expansion card   |



| Model                                     | EC-2AD2DA   |
|---|---|
| Product description                       | TS/TM series analog expansion card, 2-channel analog input, 2-channel analog output |
| Hot swapping                              | Not supported   |
| Number of input channels                  | 2 channels  |
| Voltage input range                       | 0~10V, 0~5V, 1~5V   |
| Current input range                       | 0~20mA, 4~20mA  |
| Input accuracy (normal temperature 25°C)  | Voltage ±1%, Current ±1%  |
| Input accuracy (full temperature range)   | Voltage ±3%, Current ±3%  |
| Input resolution                          | 12bit   |
| Digital input                             | 0~20000   |
| Number of output channels                 | 2 channels  |
| Voltage output range                      | 0~10V, 0~5V, 1~5V   |
| Current output range                      | 0~20mA, 4~20mA  |
| Output accuracy (normal temperature 25°C) | ±1%   |
| Output accuracy (full temperature range)  | ±5%   |
| Output resolution                         | 12bit   |
| Digital output                            | 0~20000   |

## IVC PLC product list

| Material code                     | Model          | Description  | Dimension       |
|-----------------------------------|----------------|--|-----------------|
| <b>● IVC1L main module ●</b>      |                |  |                 |
| 11060-00076                       | IVC1L-0806MAR  | 8 digital inputs, 6 relay outputs, AC220V power supply                                       | 135×90×81.2mm   |
| 11060-00077                       | IVC1L-0806MAT  | 8 digital inputs, 6 transistor outputs, AC220V power supply                                  | 135×90×81.2mm   |
| 11060-00070                       | IVC1L-1410MAR  | 14 digital inputs, 10 relay outputs, AC220V power supply                                     | 135×90×81.2mm   |
| 11060-00071                       | IVC1L-1410MAT  | 14 digital inputs, 10 transistor outputs, AC220V power supply                                | 135×90×81.2mm   |
| 11060-00068                       | IVC1L-1614MAR  | 16 digital inputs, 14 relay outputs, AC220V power supply                                     | 150×90×81.2mm   |
| 11060-00069                       | IVC1L-1614MAT  | 16 digital inputs, 14 transistor outputs, AC220V power supply                                | 150×90×81.2mm   |
| 11060-00066                       | IVC1L-1614MAR1 | 16 digital inputs, 14 relay outputs, integrated 2AI and 1AO, AC220V power supply             | 182×90×81.2mm   |
| 11060-00067                       | IVC1L-1614MAT1 | 16 digital inputs, 14 transistor outputs, integrated 2AI and 1AO, AC220V power supply        | 182×90×81.2mm   |
| 11060-00064                       | IVC1L-2416MAR  | 24 digital inputs, 16 relay outputs, AC220V power supply                                     | 182×90×81.2mm   |
| 11060-00065                       | IVC1L-2416MAT  | 24 digital inputs, 16 transistor outputs, AC220V power supply                                | 182×90×81.2mm   |
| 11060-00062                       | IVC1L-3624MAR  | 36 digital inputs, 24 relay outputs, AC220V power supply                                     | 224.5×90×81.2mm |
| 11060-00063                       | IVC1L-3624MAT  | 36 digital inputs, 24 transistor outputs, AC220V power supply                                | 224.5×90×81.2mm |
| 11060-00198                       | IVC1L-1616MAR6 | 24 digital inputs, 16 relay outputs, integrated 2 thermal resistor (PT), AC220V power supply | 182×90×81.2mm   |
| 11060-00139                       | IVC1L-0806MDR  | 8 digital inputs, 6 relay outputs, DC24V power supply  | 135×90×81.2mm   |
| 11060-00138                       | IVC1L-0806MDT  | 8 digital inputs, 6 transistor outputs, DC24V power supply                                   | 135×90×81.2mm   |
| 11060-00143                       | IVC1L-1410MDR  | 14 digital inputs, 10 relay outputs, DC24V power supply                                      | 135×90×81.2mm   |
| 11060-00142                       | IVC1L-1410MDT  | 14 digital inputs, 10 transistor outputs, DC24V power supply                                 | 135×90×81.2mm   |
| 11060-00145                       | IVC1L-1614MDR  | 16 digital inputs, 14 relay outputs, DC24V power supply                                      | 150×90×81.2mm   |
| 11060-00144                       | IVC1L-1614MDT  | 16 digital inputs, 14 transistor outputs, DC24V power supply                                 | 150×90×81.2mm   |
| 11060-00147                       | IVC1L-2416MDR  | 24 digital inputs, 16 relay outputs, DC24V power supply                                      | 182×90×81.2mm   |
| 11060-00146                       | IVC1L-2416MDT  | 24 digital inputs, 16 transistor outputs, DC24V power supply                                 | 182×90×81.2mm   |
| 11060-00149                       | IVC1L-3624MDR  | 36 digital inputs, 24 relay outputs, DC24V power supply                                      | 224.5×90×81.2mm |
| 11060-00148                       | IVC1L-3624MDT  | 36 digital inputs, 24 transistor outputs, DC24V power supply                                 | 224.5×90×81.2mm |
| <b>● IVC1L extension module ●</b> |                |  |                 |
| 11060-00207                       | IVC1L-0808ENR  | 8 digital inputs, 8 relay outputs  | 61×90×81.2mm    |
| 11060-00204                       | IVC1L-0808ENT  | 8 digital inputs, 8 transistor outputs   | 61×90×81.2mm    |
| 11060-00205                       | IVC1L-1600ENN  | 16 digital inputs  | 61×90×81.2mm    |
| 11060-00217                       | IVC1L-0016ENT  | 16 transistor outputs  | 61×90×81.2mm    |
| 11060-00206                       | IVC1L-0016ENR  | 16 relay outputs   | 61×90×81.2mm    |
| 11060-00214                       | IVC1L-2AD      | 2 analog input   | 61×90×81.2mm    |
| 11060-00212                       | IVC1L-2DA      | 2 analog outputs   | 61×90×81.2mm    |
| 11060-00215                       | IVC1L-2TC      | 2 thermocouple   | 61×90×81.2mm    |
| 11060-00216                       | IVC1L-2PT      | 2 thermal resistance   | 61×90×81.2mm    |
| 11060-00209                       | IVC1L-4AD      | 4 analog inputs  | 61×90×81.2mm    |
| 11060-00208                       | IVC1L-4DA      | 4 analog outputs   | 61×90×81.2mm    |
| 11060-00210                       | IVC1L-4TC      | 4 thermocouple   | 61×90×81.2mm    |
| 11060-00213                       | IVC1L-4PT      | 4 thermal resistance   | 61×90×81.2mm    |
| 11060-00211                       | IVC1L-5AM      | 4 analog inputs, 1 analog output   | 61×90×81.2mm    |

| Material code                                 | Model      | Description   | Dimension |
|---|------------|---|-----------|
| <b>● IVC PLC spare part ●</b>                 |            |   |           |
| 67005-00004                                   | IVC-SL1    | PLC-VS HMI 232 communication cable (2m)   | 2m        |
| 67005-00001                                   | IVC-SL2    | PLC download cable, USB-RS232 (Port0)(2m)   | 2m        |
| 67005-00002                                   | IVC-SL3    | PLC-VT/VK/VA HMI 232 communication cable (3m)   | 3m        |
| 67005-00003                                   | IVC-SL4    | HMI download cable, available for VT/VK/VA/VS series (2m)   | 2m        |
| 67005-00259                                   | IVC-SL5    | PLC-VT/VK/VA HMI 232 communication cable (7m)   | 7m        |
| 67005-00391                                   | IVC-SL8    | PLC-VS HMI 232 communication cable (7m)   | 7m        |
| 67005-00392                                   | IVC-SL9    | IVC1L extension cable (1m)  | 1m        |
| <b>● TS600 main module ●</b>                  |            |   |           |
| 11060-00315                                   | TS611      | 16 inputs and 16 transistor outputs, 1×USB (TypeC), 2×RS485, 8 channels of 200K input, 16 channels of 200K output, up to 8 axes (pulse axes)  | CE        |
| 11060-00328                                   | TS620      | 8 inputs and 8 transistor (NPN) outputs, 1×USB (Type-C), 2×RS485, 8 channels of 200K input, 8 channels of 200K output, 1×EtherNet, up to 4 axes (pulse axes)                                | CE        |
| 11060-00331                                   | TS620R     | 8 inputs and 6 relay outputs, 1×USB (Type-C), 2×RS485, eight 200K inputs, 1×EtherNet  | CE        |
| 11060-00318                                   | TS621      | 16 inputs and 16 transistor outputs, 1×USB (Type-C), 2×RS485, 8 channels of 200K input, 16 channels of 200K output, 2×EtherNet, up to 8 axes (pulse axes)                                   | CE        |
| 11060-00323                                   | TS621P     | 16 inputs and 16 transistor (PNP) outputs, 1×USB (Type-C), 2×RS485, 8 channels of 200K input, 16 channels of 200K output, 2×EtherNet, up to 8 axes (pulse axes)                             | CE        |
| 11060-00329                                   | TS630      | 8 inputs and 8 transistor (NPN) outputs, 1×USB (Type-C), 2×RS485, 8 channels of 200K input, 8 channels of 200K output, 1×EtherNet, 1×EtherCAT, up to 12 axes (8 bus axes + 4 pulse axes)    | CE        |
| 11060-00317                                   | TS633      | 16 inputs and 16 transistor outputs, 1×USB (Type-C), 2×RS485, 8 channels of 200K input, 8 channels of 200K output, 2×EtherNet, 1×EtherCAT, up to 12 axes (8 bus axes + 4 pulse axes)        | CE        |
| 11060-00324                                   | TS633P     | 16 inputs and 16 transistor (PNP) outputs, 1×USB (Type-C), 2×RS485, 8 channels of 200K input, 8 channels of 200K output, 2×EtherNet, 1×EtherCAT, up to 12 axes (8 bus axes + 4 pulse axes)  | CE        |
| 11060-00316                                   | TS634      | 16 inputs and 16 transistor outputs, 1×USB (Type-C), 2×RS485, 8 channels of 200K input, 8 channels of 200K output, 2×EtherNet, 1×EtherCAT, up to 20 axes (16 bus axes + 4 pulse axes)       | CE        |
| 11060-00325                                   | TS634P     | 16 inputs and 16 transistor (PNP) outputs, 1×USB (Type-C), 2×RS485, 8 channels of 200K input, 8 channels of 200K output, 2×EtherNet, 1×EtherCAT, up to 20 axes (16 bus axes + 4 pulse axes) | CE        |
| 11060-00312                                   | TS635      | 16 inputs and 16 transistor outputs, 1×USB (Type-C), 2×RS485, 8 channels of 200K input, 8 channels of 200K output, 2×EtherNet, 1×EtherCAT, up to 36 axes (32 bus axes + 4 pulse axes)       | CE        |
| <b>● TS600 series expansion card module ●</b> |            |   |           |
| 11060-00313                                   | TS-CAN-232 | TS600 series expansion card TS-CAN-232, which supports Micro SD cards, CANopen bus, and one channel of RS232 communication  | CE        |
| 11060-00332                                   | EC-CAN     | TS/TM series expansion card, 2×RJ45, 1×MicroSD card (SD card only supports TS series)   | CE        |
| 11060-00333                                   | EC-2AD2DA  | TS/TM series analog expansion card, 2-channel analog input, 2-channel analog output   | CE        |

# Medium PLC

Industrial control technology based on the CODESYS platform



The TM700 series high-performance programmable controller is mainly designed for scenarios with high motion control requirements and complex control networks. It has significant improvements in control performance, communication capabilities, and programming efficiency, allowing you to build control networks flexibly. Through OPCUA, the data interaction with the information layer is more convenient, further improving device takt time, shortening development cycles, and bringing an enhanced experience.

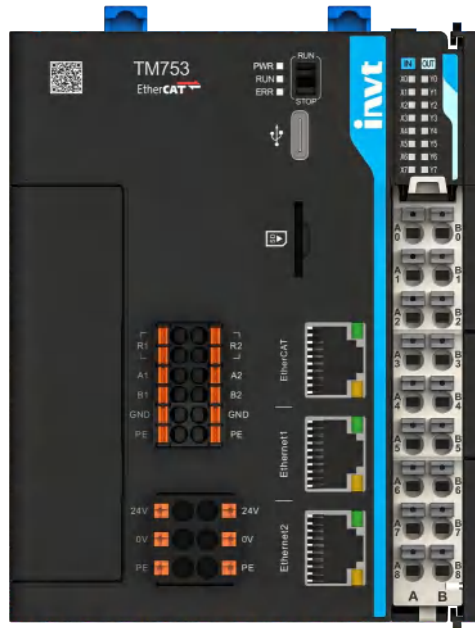

### Powerful motion control

EtherCAT bus control is available, with standard PLCOpen motion control function, supported by industry process packages, enabling rapid development of motion control programs.



### Informationization

The module supports multiple international standard communication networks, flexible construction of multi-level open communication networks, and seamless integration with upper level systems such as MES/ERP through OPC UA.



### Cloud collaboration

With Extcard for functional extensions such as 4G and Wi-Fi, remote operation and maintenance and digital management of devices are available through the IWoCloud cloud platform and IWoScience IoT business system.



### Easy programming

Multiple programming languages are supported, including LD, IL, SFC, CFC, FBD, and ST, and servo and VFD debugging can be conducted through Invtmatic Studio, significantly enhancing programming efficiency.

## Powerful motion control

- 1ms@16 axes EtherCAT bus motion control, achieving multi-axis collaboration, significantly shortening the takt time
- 8 high-speed inputs and 8 high-speed outputs integrated, supporting functions such as encoder input, hardware latch, high-speed comparison output, and pulse axis. It has precise position control and is widely used in labeling, flying trigger and other scenarios



### A0-A7: 8 high-speed inputs

- Four high-speed counters
- Probe, reset, preset value input

### B0-B7: 8 high-speed outputs

- 4 groups of pulse axis
- 4 groups of PWM output
- 4 high-speed comparison outputs

- Supporting BufferMode function for smooth motion, reducing impact on machinery and improving productivity

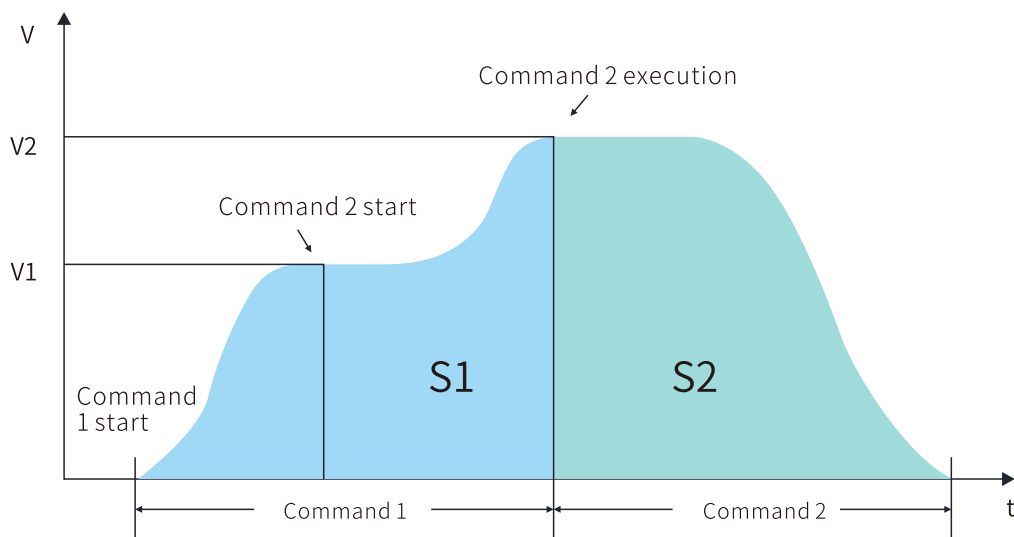

Continuous and uninterrupted BufferMode speed

- Supporting high-order motion control of electronic cams and gears

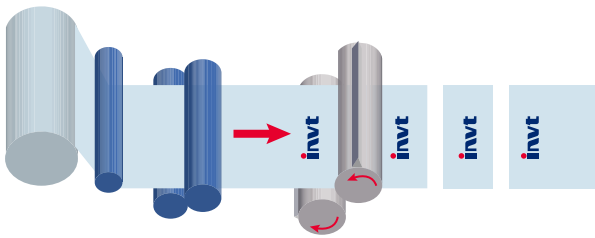

Flying shear

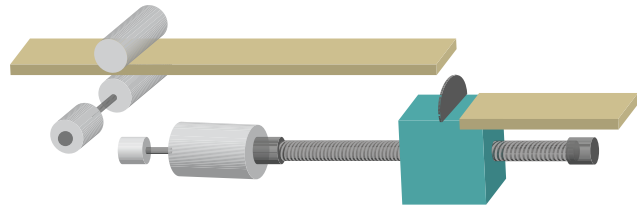

Linear flying shear

- Supporting multiple interpolation functions, such as linear interpolation, arc interpolation, and spiral interpolation

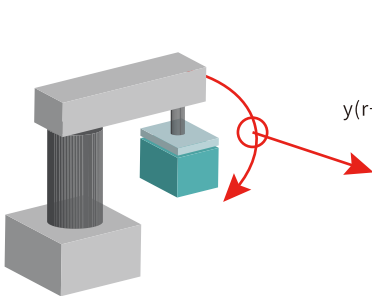

Arc interpolation

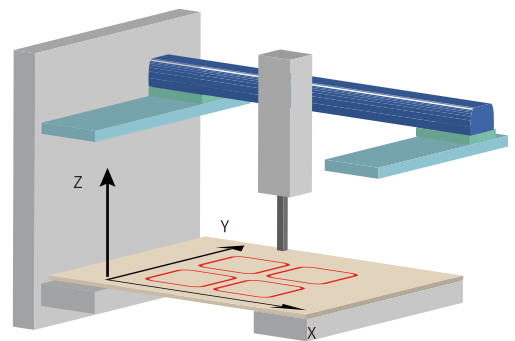
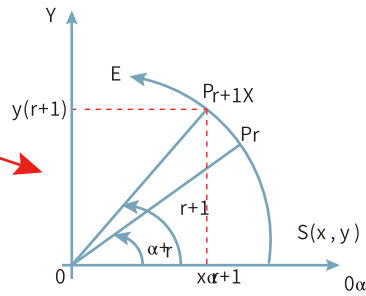

Multi-axis linear interpolation

- Supporting axis group function, with kinematic models integrating with multiple standards, easily achieving control of various types of robotic arms

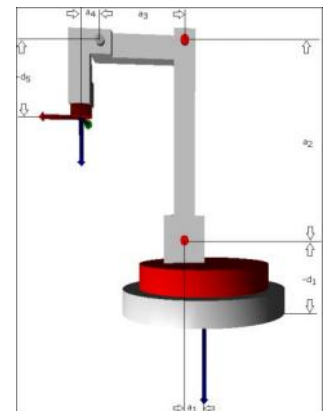
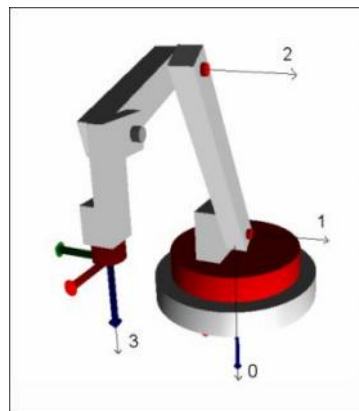
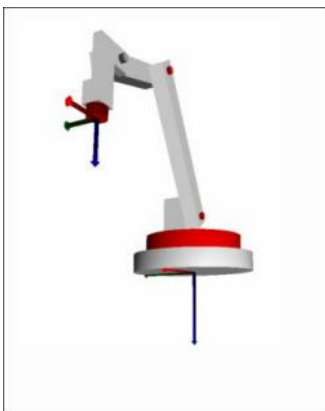

- Industry-specific process libraries, integrated with a wealth of industry-specific process instructions, reducing the difficulty of process development and shortening the solution development cycle

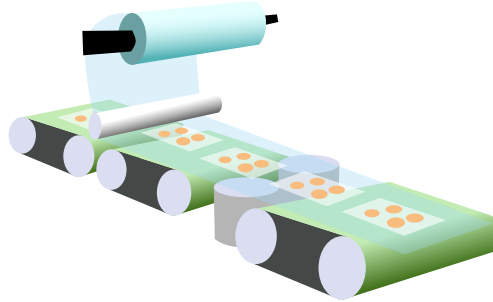

Process library for packaging industry

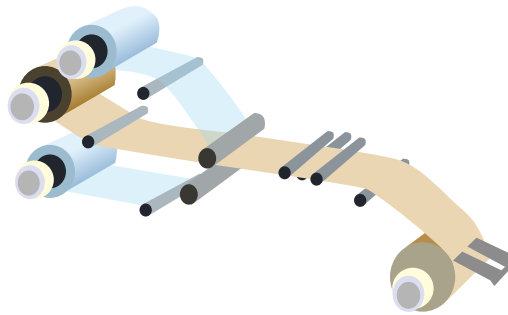

Winding and unwinding process library

### Efficient network

- Supporting rich network interfaces and protocols, EtherCAT, ModbusTCP, TCP/IP, UDP, EtherNet/IP, Modbus RTU, and CANopen, enabling a multi-level network structure and flexible construction of control network
- OPC UA, tag communication, allowing efficient information exchange with simple configuration

### Digitalization

- With the help of INVT IWoScience IoT business system, remote management, maintenance, analysis, and monitoring of equipment can be achieved. It has a friendly interface, simple operation, and complete functions, solving the problems of inconvenient management, maintenance, and monitoring in the application industry due to the complex environment where the equipment is located, making the work smarter and more efficient

### Remote O&M

- The Extcard can be used to extend functions such as CANopen, 4G, Wi-Fi, etc. It can also achieve remote PLC debugging, program updates, firmware updates, and other functions with just one click through INVT WoCloud cloud platform

## Remote O&M

- The Extcard can be used to extend functions such as CANopen, 4G, Wi-Fi, etc. It can also achieve remote PLC debugging, program updates, firmware updates, and other functions with just one click through INVT WoCloud cloud platform

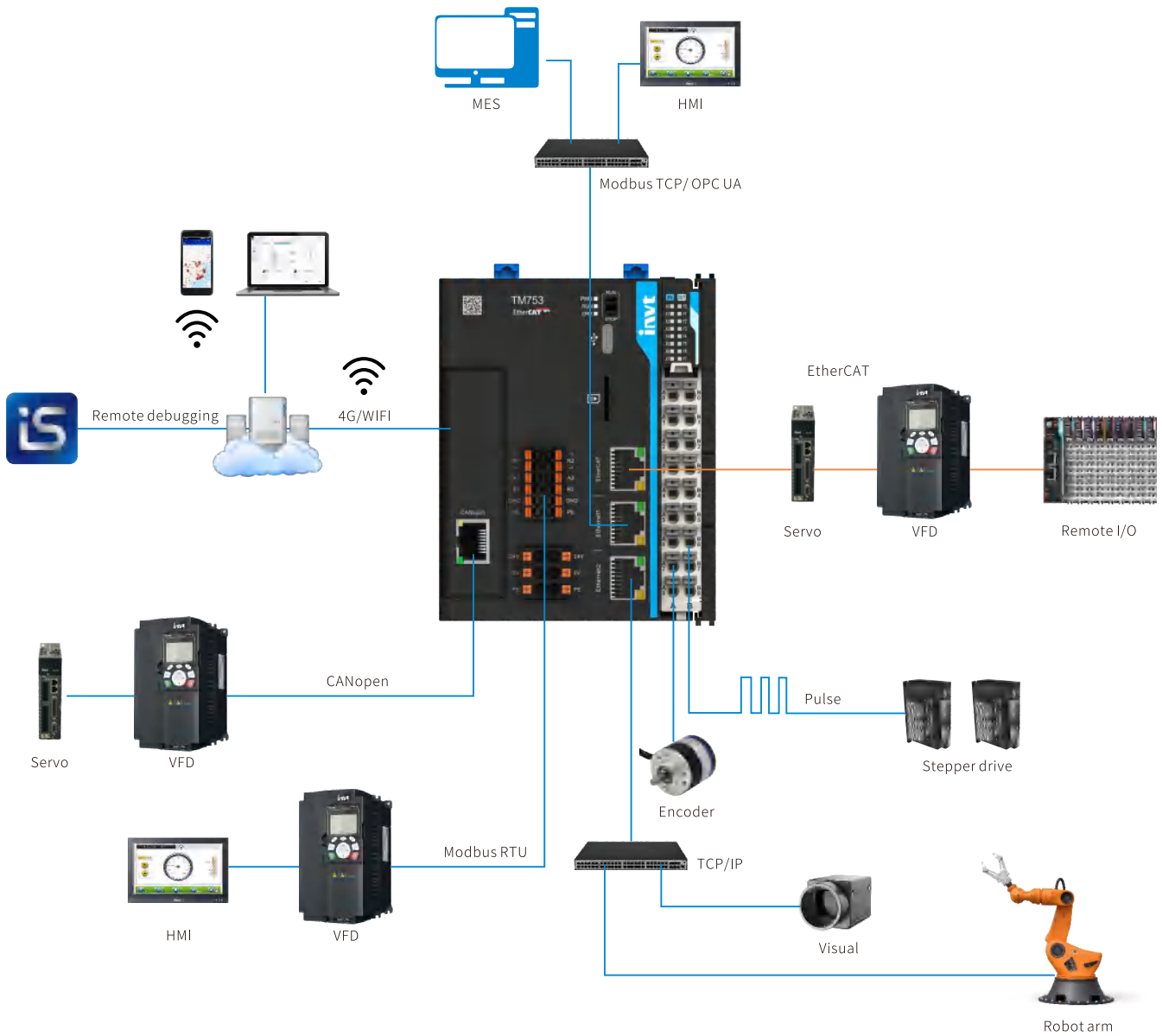

Easy programming

- Visibility of variable usage helps with program optimization and troubleshooting

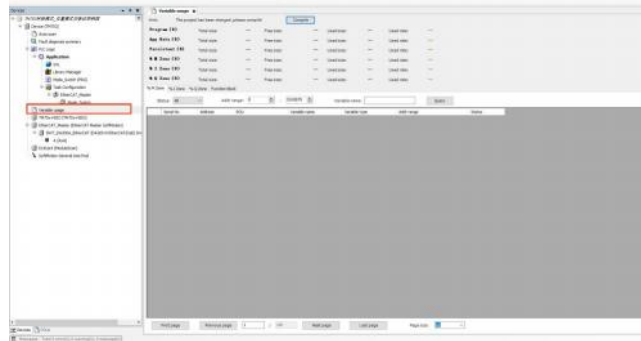

- Host controller reads and writes servo function codes and VFD function codes, making it easy to debug

| Function Code | Parameter                       | Comment | Address | Default Value | Unit | Bit Type | Bit Mask | Bit Shift | Display                         |
|---------------|---------------------------------|---------|---------|---------------|------|----------|----------|-----------|---------------------------------|
| FD.01         | Power On                        |         | 1       | 0             |      | Bit      | 0        | 0         | Power On                        |
| FD.02         | Emergency stop selection        |         | 1       | 0             |      | Bit      | 0        | 0         | Emergency stop selection        |
| FD.03         | Reset Forward direction         |         | 1       | 0             |      | Bit      | 0        | 0         | Reset Forward direction         |
| FD.04         | Control mode selection          |         | 1       | 0             |      | Bit      | 0        | 0         | Control mode selection          |
| FD.05         | Internal sensor enable          |         | 1       | 0             |      | Bit      | 0        | 0         | Internal sensor enable          |
| FD.06         | Axis speed                      |         | 1       | 0             |      | Bit      | 0        | 0         | Axis speed                      |
| FD.07         | Number of encoder pulses output |         | 1       | 0             |      | Bit      | 0        | 0         | Number of encoder pulses output |
| FD.08         | Encoder resolution              |         | 1       | 0             |      | Bit      | 0        | 0         | Encoder resolution              |
| FD.09         | Encoder resolution              |         | 1       | 0             |      | Bit      | 0        | 0         | Encoder resolution              |
| FD.10         | Encoder resolution              |         | 1       | 0             |      | Bit      | 0        | 0         | Encoder resolution              |
| FD.11         | Encoder resolution              |         | 1       | 0             |      | Bit      | 0        | 0         | Encoder resolution              |
| FD.12         | Encoder resolution              |         | 1       | 0             |      | Bit      | 0        | 0         | Encoder resolution              |
| FD.13         | Encoder resolution              |         | 1       | 0             |      | Bit      | 0        | 0         | Encoder resolution              |
| FD.14         | Encoder resolution              |         | 1       | 0             |      | Bit      | 0        | 0         | Encoder resolution              |
| FD.15         | Encoder resolution              |         | 1       | 0             |      | Bit      | 0        | 0         | Encoder resolution              |
| FD.16         | Encoder resolution              |         | 1       | 0             |      | Bit      | 0        | 0         | Encoder resolution              |
| FD.17         | Encoder resolution              |         | 1       | 0             |      | Bit      | 0        | 0         | Encoder resolution              |
| FD.18         | Encoder resolution              |         | 1       | 0             |      | Bit      | 0        | 0         | Encoder resolution              |
| FD.19         | Encoder resolution              |         | 1       | 0             |      | Bit      | 0        | 0         | Encoder resolution              |
| FD.20         | Encoder resolution              |         | 1       | 0             |      | Bit      | 0        | 0         | Encoder resolution              |
| FD.21         | Encoder resolution              |         | 1       | 0             |      | Bit      | 0        | 0         | Encoder resolution              |
| FD.22         | Encoder resolution              |         | 1       | 0             |      | Bit      | 0        | 0         | Encoder resolution              |
| FD.23         | Encoder resolution              |         | 1       | 0             |      | Bit      | 0        | 0         | Encoder resolution              |
| FD.24         | Encoder resolution              |         | 1       | 0             |      | Bit      | 0        | 0         | Encoder resolution              |
| FD.25         | Encoder resolution              |         | 1       | 0             |      | Bit      | 0        | 0         | Encoder resolution              |
| FD.26         | Encoder resolution              |         | 1       | 0             |      | Bit      | 0        | 0         | Encoder resolution              |
| FD.27         | Encoder resolution              |         | 1       | 0             |      | Bit      | 0        | 0         | Encoder resolution              |
| FD.28         | Encoder resolution              |         | 1       | 0             |      | Bit      | 0        | 0         | Encoder resolution              |
| FD.29         | Encoder resolution              |         | 1       | 0             |      | Bit      | 0        | 0         | Encoder resolution              |
| FD.30         | Encoder resolution              |         | 1       | 0             |      | Bit      | 0        | 0         | Encoder resolution              |
| FD.31         | Encoder resolution              |         | 1       | 0             |      | Bit      | 0        | 0         | Encoder resolution              |
| FD.32         | Encoder resolution              |         | 1       | 0             |      | Bit      | 0        | 0         | Encoder resolution              |
| FD.33         | Encoder resolution              |         | 1       | 0             |      | Bit      | 0        | 0         | Encoder resolution              |
| FD.34         | Encoder resolution              |         | 1       | 0             |      | Bit      | 0        | 0         | Encoder resolution              |
| FD.35         | Encoder resolution              |         | 1       | 0             |      | Bit      | 0        | 0         | Encoder resolution              |
| FD.36         | Encoder resolution              |         | 1       | 0             |      | Bit      | 0        | 0         | Encoder resolution              |
| FD.37         | Encoder resolution              |         | 1       | 0             |      | Bit      | 0        | 0         | Encoder resolution              |
| FD.38         | Encoder resolution              |         | 1       | 0             |      | Bit      | 0        | 0         | Encoder resolution              |
| FD.39         | Encoder resolution              |         | 1       | 0             |      | Bit      | 0        | 0         | Encoder resolution              |
| FD.40         | Encoder resolution              |         | 1       | 0             |      | Bit      | 0        | 0         | Encoder resolution              |

- ⊗ Axis unit conversions, clear and concise

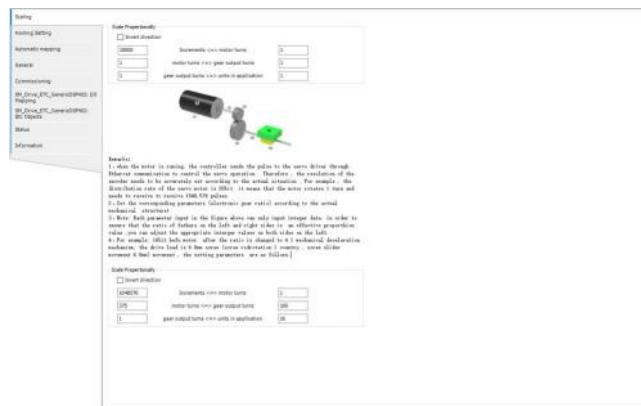

- Homing method, easy to understand

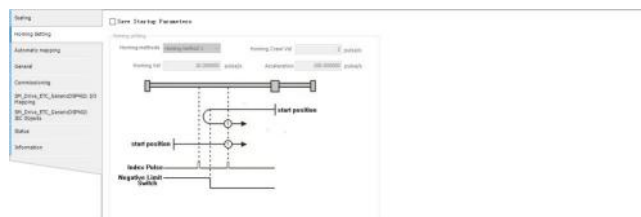

## Technical specifications

| Model                                      | TM750   | TM751                          | TM752                            | TM753                           |
|--|---|--------------------------------|----------------------------------|---------------------------------|
| Rated working voltage                      | DC24V(-15%~+20%)  |                                |                                  |                                 |
| <b>Memory</b>                              |   |                                |                                  |                                 |
| Program capacity                           | 20MB  |                                |                                  |                                 |
| Data capacity                              | 64MB  |                                |                                  |                                 |
| Capacity of data saved at power failure    | 1MB   |                                |                                  |                                 |
| Max. capacity of SD card                   | 32G   |                                |                                  |                                 |
| <b>I/O</b>                                 |   |                                |                                  |                                 |
| High-speed I/O                             | 8 high-speed inputs and 8 high-speed outputs  |                                |                                  |                                 |
| Max. number of local expansion modules     | 16  |                                |                                  |                                 |
| Max. number of I/O points                  | Local   | 512                            |                                  |                                 |
|  | EtherCAT bus  | 32000                          |                                  |                                 |
| High-speed input                           | 4 channels of high-speed counter, supporting 1PH, A/B phase, CW/CCW, and pulse+direction, in which A/B phase supports frequency multiplication by 1, 2, and 4 |                                |                                  |                                 |
| High-speed output                          | 8 channels of 200kHz high-speed output, supporting 4-axis pulse motion control  |                                |                                  |                                 |
| Support for I/O interruption               | 8 channels of high-speed interrupt input  |                                |                                  |                                 |
| PWM output                                 | 4 channels of PWM output  |                                |                                  |                                 |
| <b>Communication network and interface</b> |   |                                |                                  |                                 |
| Ethernet                                   | ×2, RJ45, 100Base-TX, supporting PLC software download, ModbusTCP, TCP/IP, and OPC UA protocols   |                                |                                  |                                 |
| EtherCAT                                   | 1×RJ45, 100Base-TX, with the distance between two slave nodes less than 100m  |                                |                                  |                                 |
| Serial communication (RS485)               | ×2, Modbus RTU primary and secondary nodes, in-line terminal  |                                |                                  |                                 |
| USB  | ×1, Type-C, for PC communication, program download and debugging  |                                |                                  |                                 |
| Storage card                               | 1×Micro SD, for firmware upgrade, application and file transmission   |                                |                                  |                                 |
| Communication expansion                    | CANopen   |                                |                                  |                                 |
| <b>Motion control</b>                      |   |                                |                                  |                                 |
| Max. number of control axes                | 4 axes(EtherCAT)+4 axes(pulse)  | 8 axes(EtherCAT)+4 axes(pulse) | 16 axes(EtherCAT)+4 axes(pulse)  | 32 axes(EtherCAT)+4 axes(pulse) |
| Motion control function                    | Point-to-point (PTP) motion, interpolation motion (linear, arc), electronic gear, electronic cam (flying shear, linear flying shear), and so on               |                                |                                  |                                 |
| <b>Configuration programming</b>           |   |                                |                                  |                                 |
| Programming platform                       | Invtmatic Studio 1.3.5 and above  |                                |                                  |                                 |
| Programming languages                      | IL、ST、FBD、LD、CFC、SFC  |                                |                                  |                                 |
| <b>Basic specifications</b>                |   |                                |                                  |                                 |
| Running environment temperature            | -10~55°C  |                                |                                  |                                 |
| Running environment humidity               | 10%~95% (no condensation)   |                                |                                  |                                 |
| Storage temperature                        | -40~70°C  |                                |                                  |                                 |
| Storage humidity                           | 10%~100% (no condensation)  |                                |                                  |                                 |
| IP rating                                  | IP20  |                                |                                  |                                 |
| Application environment                    | No corrosive gas  |                                |                                  |                                 |
| Altitude                                   | 2000m or lower  |                                |                                  |                                 |
| Installation manner                        | In control cabinet  |                                |                                  |                                 |
| Pollution degree                           | Degree 2 or lower, compliant with IEC 61131-2   |                                |                                  |                                 |
| Surge                                      | 2kV   |                                |                                  |                                 |
| Anti-interference                          | 2kV voltage-withstand power cable (compliant with IEC61000-4-4)   |                                |                                  |                                 |
| ESD class                                  | 6kV CD or 8kV AD  |                                |                                  |                                 |
| Vibration resistant                        | 5~8.5Hz, vibration amplitude of 3.5mm; 8.5~150Hz, acceleration of 10m/s <sup>2</sup> ; X/Y/Z axis, 10cycles   |                                |                                  |                                 |
| <b>Dimensions and weight</b>               |   |                                |                                  |                                 |
| Dimensions (W×H×D)                         | 80.5×105×96mm (without terminal)  |                                | 80.5×105×114.2mm (with terminal) |                                 |
| Weight (kg)                                | 0.39  |                                |                                  |                                 |

## EC-CAN product image



| Model                           | EC-CAN   |
|---------------------------------|--|
| Product description             | TS/TM series CAN expansion card, with two RJ45 interfaces and one MicroSD card interface (Only the TS series can use the SD card)                    |
| Ingress protection (IP) rating  | Ip20   |
| Working temperature             | -20°C~55°C   |
| Terminal resistor               | Built-in terminal resistor, which can be selected through the dial switch  |
| Baud rate                       | 1Mbps: Distance<20m<br>500Kbps: Distance<80m<br>250Kbps: Distance<150m<br>125Kbps: Distance<300m<br>100Kbps: Distance<500m<br>50Kbps: Distance<1000m |
| SD card capacity                | Up to 32GB   |
| SD card specifications          | Micro SD   |
| SD card communication interface | SDIO   |
| Hot swapping                    | Supported by SD cards, but not supported by the expansion card   |



| Model   | EC-2AD2DA   |
|---|---|
| Product description                           | TS/TM series analog expansion card, with 2-channel analog input and 2-channel analog output |
| Hot swapping                                  | Not supported   |
| Number of input channels                      | 2 channels  |
| Voltage input range                           | 0-10V, 0-5V, and 1-5V   |
| Current input range                           | 0-20mA and 4-20mA   |
| Input accuracy (at room temperature of 25°C)  | Voltage±1%<br>Current±1%  |
| Input accuracy (in full temperature range)    | Voltage±3%<br>Current±3%  |
| Input resolution                              | 12-bit  |
| Digital input                                 | 0-20000   |
| Number of output channels                     | 2 channels  |
| Output voltage range                          | 0-10V, 0-5V, and 1-5V   |
| Output current range                          | 0-20mA and 4-20mA   |
| Output Accuracy (at room temperature of 25°C) | ±1%   |
| Output accuracy (in full temperature range)   | ±5%   |
| Output resolution                             | 12-bit  |
| Digital output                                | 0-20000   |

## Product dimensions

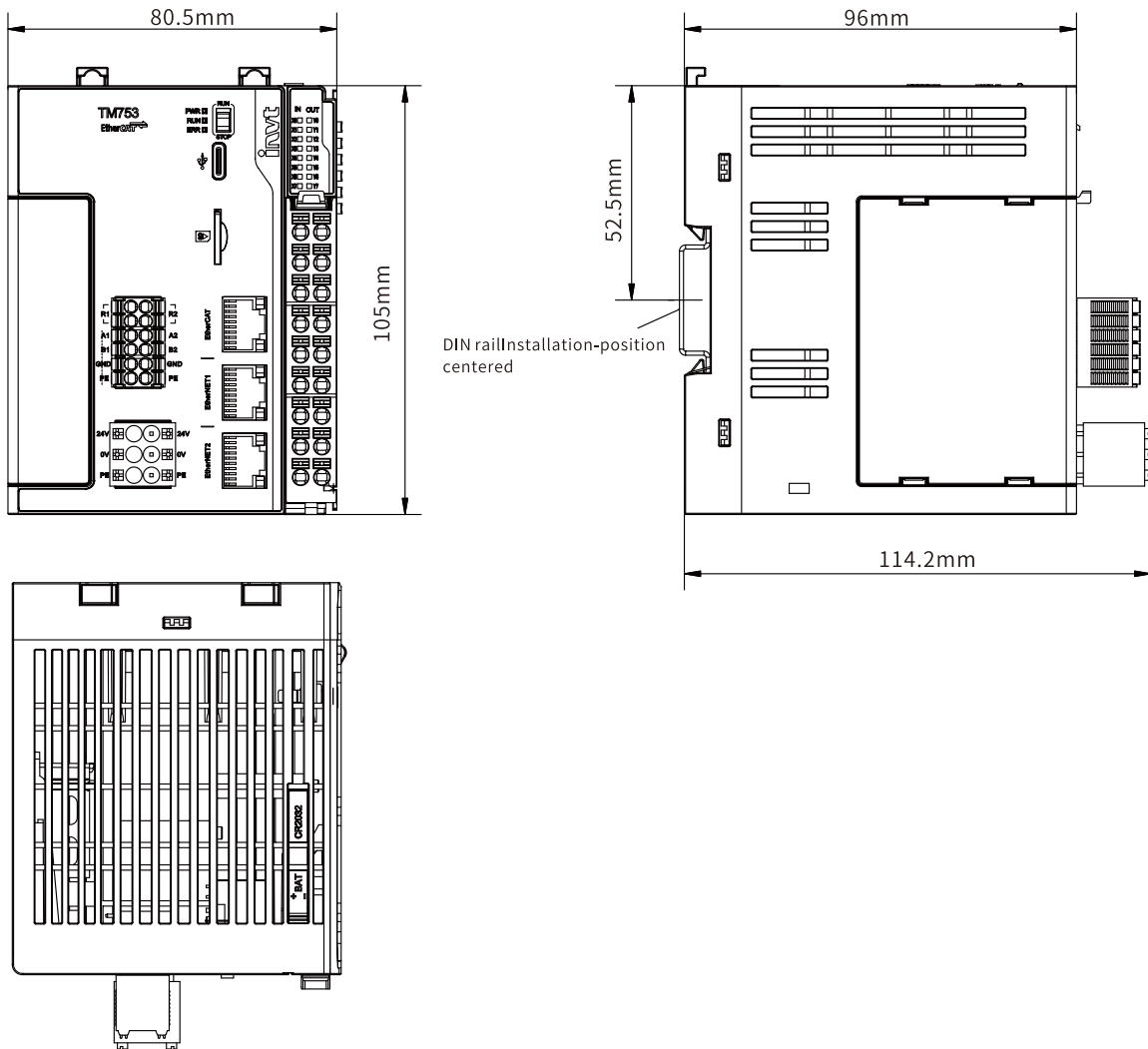

## Product list

| Ordering code | Model     | Description  | Dimension        |
|---------------|-----------|--|------------------|
| 11015-00024   | TM750     | CPU, 4-axis, 1×EtherCAT, 2×Ethernet, 2×RS485, 8-in and 8-out high-speed I/O, 24VDC; RoHS   | 80.5×105×114.2mm |
| 11015-00025   | TM751     | CPU, 8-axis, 1×EtherCAT, 2×Ethernet, 2×RS485, 8-in and 8-out high-speed I/O, 24VDC; RoHS   | 80.5×105×114.2mm |
| 11015-00026   | TM752     | CPU, 16-axis, 1×EtherCAT, 2×Ethernet, 2×RS485, 8-in and 8-out high-speed I/O, 24VDC; RoHS  | 80.5×105×114.2mm |
| 11015-00023   | TM753     | CPU, 32-axis, 1×EtherCAT, 2×Ethernet, 2×RS485, 8-in and 8-out high-speed I/O, 24VDC; RoHS  | 80.5×105×114.2mm |
| 11060-00332   | EC-CAN    | TS/TM series CAN expansion card, with two RJ45 interfaces and one MicroSD card interface (SD card interface only supports TS series) | 70.8×20×53.5mm   |
| 11060-00333   | EC-2AD2DA | TS/TM series analog expansion card, with 2-channel analog input and 2-channel analog output  | 70.8×20×53.5mm   |

# X86 Controller

Industrial controller based on PC\_Based and CODESYS

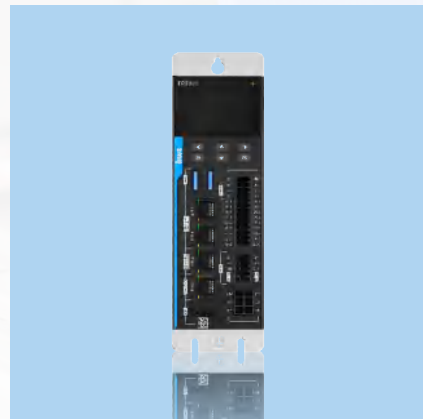

# TP2000 SERIES

The TP2000 series intelligent controller is a high-performance and production-line-level controller based on the x86 hardware platform and fully compliant with the PLCopen standard. Supporting up to 128 axes, it delivers powerful performance and flexible networking, enabling complex multi-axis motion control and large-scale logic control with ease. It is well suited for both discrete and process automation applications. It can be widely used in industries such as printing, packaging, food, lithium battery, 3C, photovoltaic, woodworking, small to medium-sized production lines, and process control.



## Powerful performance

500µs @ 32 axes high-speed response, with bus synchronization control for up to 128 axes, achieving higher precision and shorter processing cycle. o medium-sized production lines, and process control.



## Seamless connectivity

Supports industrial protocols such as EtherCAT, OPC UA, and EtherNet/IP, enabling seamless integration with mainstream devices and breaking down brand barriers.



## Dual-domain architecture

Physically isolated dual master stations for high and low real-time task domain processing, ensuring no interference and maximizing hardware performance.



## Ring network redundancy

In the event of a single node cable failure, the system can continue running without downtime, enhancing system stability and reducing downtime losses.



## Advanced motion control

Functions such as Buffermode, G-code, and robotic arms enable multi-scenario integration.



## Information visualization

TargetVisu, web-based visualization, and onboard color screens allow real-time access to device information.



\*Expected to be officially launched in Q4 2025

## Powerful performance

- Minimum 250µs @ 16-axis synchronization cycle, 500µs @ 32-axis motion control, jitter<20µs, ensuring stability and precision.
- Supports up to 128 axes bus control, capable of handling complex devices with ease
- Supports 125 I/O slaves, with logic control capacity up to 128,000 points

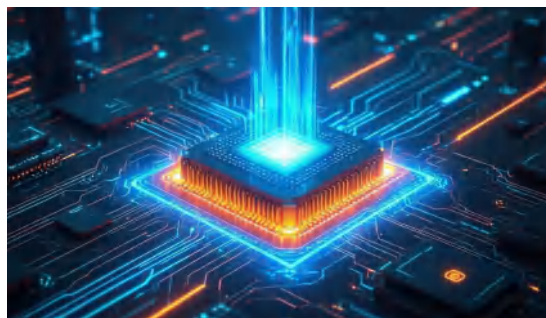

## Seamless connectivity

- Supports a wide range of interfaces and protocols including EtherCAT, OPC UA, EtherNet/IP, Profinet (PN) master, Modbus TCP, TCP/IP, UDP, and Modbus RTU, enabling seamless integration with third-party devices.
- The Ethernet interface comes with an independent IP by default, ensuring data isolation and safe operation.
- The Ethernet interface supports the soft switch function, simplifying system configuration and offering flexibility and convenience.

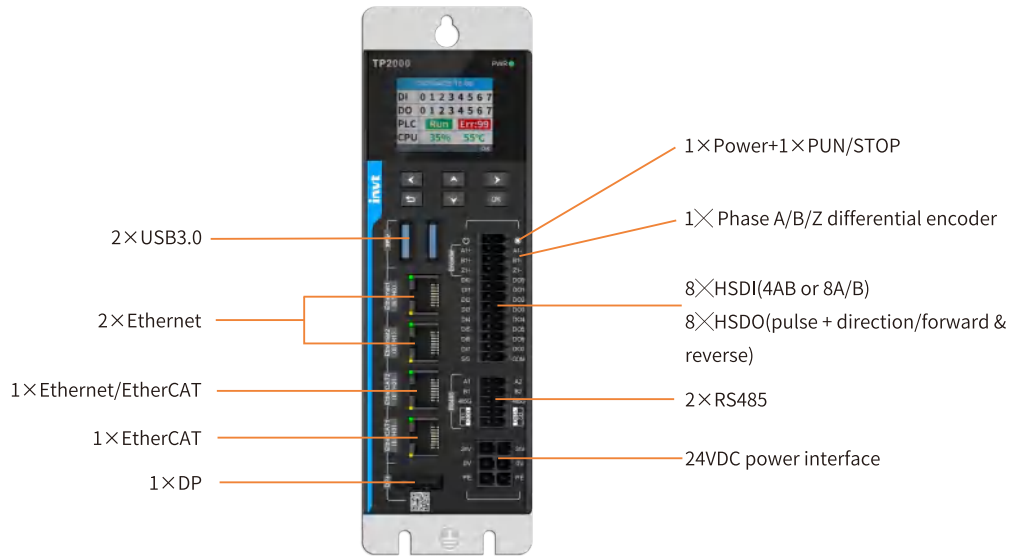

## Dual-domain architecture

- Physically isolated dual master stations, with high and low real-time task domain processing, maximizing hardware performance.
- Cost-effective integration. One unit replaces two traditional PLCs, reducing hardware costs by 50% and eliminating communication delays between PLCs.
- Fault isolation. Automatic isolation of faults within a single domain, preventing system-wide failure.

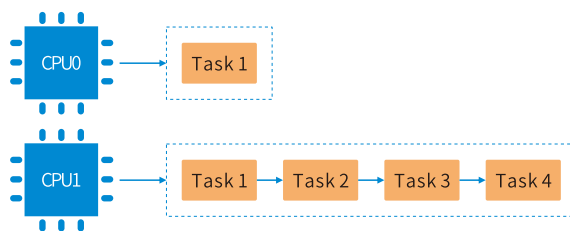

## Cable redundancy

- In the event of a single node cable failure, the system can continue running without downtime, enhancing system stability and reducing downtime losses.

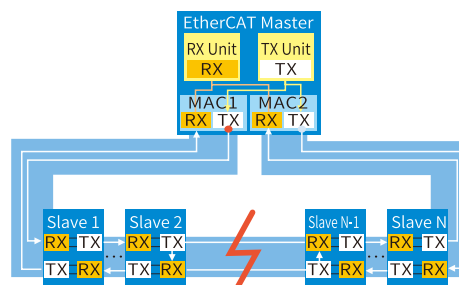

## Advanced motion control

- Functions such as Buffermode, G-code, and robotic arms enable multi-scenario and multi-station production line-level integration.

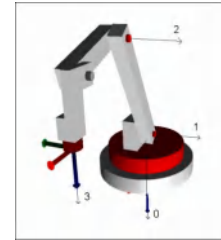
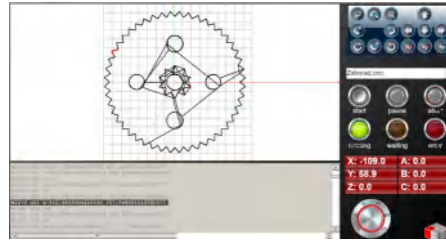
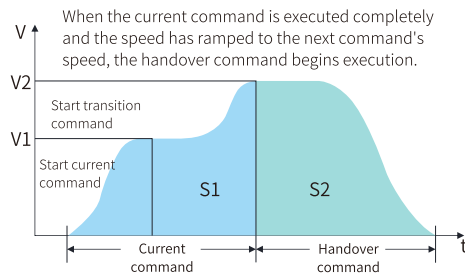

## Efficient visualization

- Running status, basic information, and alarm data are displayed intuitively for easy access.
- TargetVisu requires no third-party configuration software, allowing direct access to program variables, real-time simulation, and making application development more efficient and convenient.
- The web-based visualization function enables multi-terminal and distributed access within a local network, making system monitoring and adjustments more efficient and convenient.

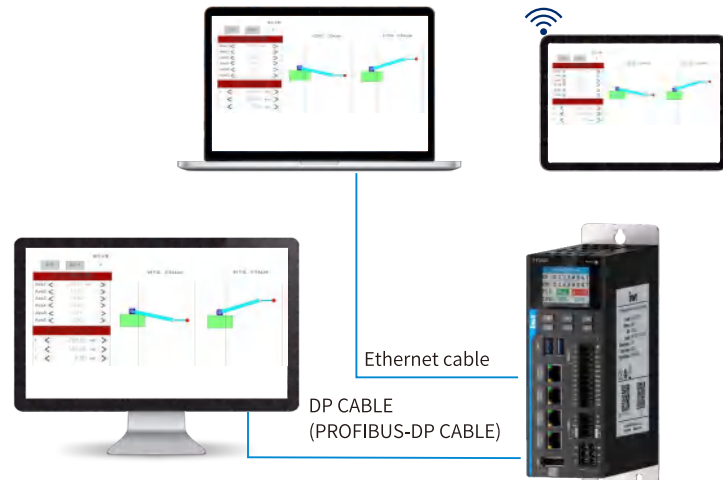

## Efficient commissioning

- Integrated servo and VFD function codes for parameter commissioning, with one-click import/export.
- EOE direct connection. PC-side servo/VFD commissioning software can directly access servos/VFDs in the EtherCAT network via their IP address, offering more comprehensive functions and significantly improving commissioning and maintenance efficiency.

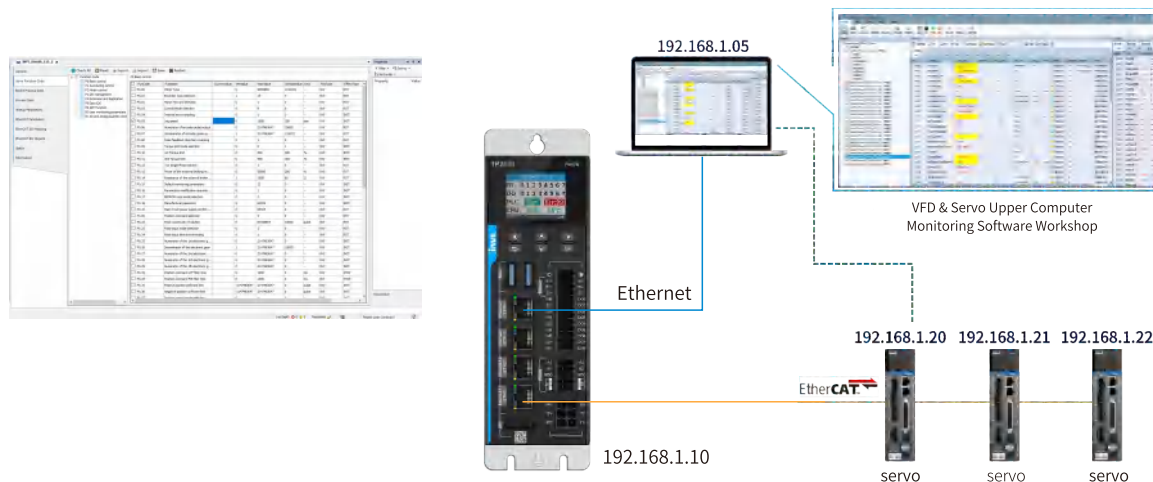

## Large-scale distributed I/O

- Supports up to 125 I/O slaves and is equipped with the Flex series I/O system, enabling large-scale I/O control with up to 128,000 points.



## Built-in UPS

- The built-in UPS offers a 1-second power transition, eliminating the need for an external UPS. It ensures 5MB of large-capacity power backup during a power failure, simplifying setup, saving space, and reducing overall system costs.



## Specifications

| codecode                                    | 11015-00043  | 11015-00042 | 11015-00045  | 11015-00032 | 11015-00044 | 11015-00046 |
|---|--|-------------|--|-------------|-------------|-------------|
| Model                                       | TP2321-1016  | TP2321-1032 | TP2422-1048  | TP2422-1064 | TP2422-1096 | TP2422-1128 |
| Rated operating voltage                     | 24VDC (-20%~+20%)  |             |  |             |             |             |
| Processor                                   | Dual-core  |             |  | Quad-core   |             |             |
| Memory                                      |  |             |  | 8GB DDR4    |             |             |
| Hard disk                                   | 64GB SSD   |             |  | 128GB SSD   |             |             |
| User program capacity                       |  |             |  | 256MB       |             |             |
| User data capacity                          |  |             |  | 256MB       |             |             |
| Power-down data retention capacity          |  |             |  | 5MB         |             |             |
| Display screen                              |  |             |  | LCD         |             |             |
| System clock                                | Users need to purchase the button battery (Model: Cr2032)  |             |  |             |             |             |
| <b>Communication network and interfaces</b> |  |             |  |             |             |             |
| Ethernet                                    | 3×RJ45 interfaces with 100/1000Base-TX, and independent IP, supporting switch and protocols such as OPC UA, EtherNet/IP, Modbus TCP, and UDP |             | 2×RJ45 interfaces with 100/1000Base-TX, and independent IP, supporting switch and protocols such as OPC UA, EtherNet/IP, Modbus TCP, and UDP |             |             |             |
| EtherCAT                                    | 1×RJ45 interface with 100/1000Base-TX<br>1×EtherCAT master   |             | 2×RJ45 interfaces with 100/1000Base-TX<br>2×EtherCAT master  |             |             |             |
| USB   | 2×USB 3.0, Type-A  |             |  |             |             |             |
| Serial communication                        | 2×RS485, in-line terminals , supporting Modbus RTU protocol  |             |  |             |             |             |
| Display interface                           | 1×DP   |             |  |             |             |             |

## Specifications

| codecode                                   | 11015-00043   | 11015-00042 | 11015-00045 | 11015-00032 | 11015-00044 | 11015-00046 |
|--|---|-------------|-------------|-------------|-------------|-------------|
| Model                                      | TP2321-1016   | TP2321-1032 | TP2422-1048 | TP2422-1064 | TP2422-1096 | TP2422-1128 |
| <b>I/O</b>                                 |   |             |             |             |             |             |
| Inputs                                     | Single-ended (Sourcing/Sinking): 8 channels, supporting 4-channel AB-phase encoder input, can be used as general inputs                   |             |             |             |             |             |
| Outputs                                    | Single-ended (Sinking): 8 channels, supporting 4-channel pulse output, can be used as general outputs                                     |             |             |             |             |             |
| Remote I/O points                          | 128,000 points (EtherCAT bus)   |             |             |             |             |             |
| <b>Motion Control</b>                      |   |             |             |             |             |             |
| Maximum number of controlled axes          | 16 axes   | 32 axes     | 48 axes     | 64 axes     | 96 axes     | 128 axes    |
| Point-to-point control                     |   |             |             | ●           |             |             |
| Interpolation motion                       |   |             |             | ●           |             |             |
| Electronic cam                             |   |             |             | ●           |             |             |
| Electronic gear                            |   |             |             | ●           |             |             |
| CNC  |   |             |             | ●           |             |             |
| ROBOT                                      |   |             |             | ●           |             |             |
| Motion control cycle                       | The EtherCAT data communication cycle uses the same control cycle   |             |             |             |             |             |
| Position units                             | Pulse count, millimeters, and inches  |             |             |             |             |             |
| <b>Redundancy</b>                          |   |             |             |             |             |             |
| Cable Redundancy                           | —   | —           | ●           | ●           | ●           | ●           |
| <b>Configuration programming</b>           |   |             |             |             |             |             |
| Programming platform                       | Invtmatic Studio 3.0 .0.7and later  |             |             |             |             |             |
| Programming language                       | IL, ST, FBD, LD, CFC, and SFC   |             |             |             |             |             |
| <b>Basic specifications</b>                |   |             |             |             |             |             |
| Installation position                      | Inside the control cabinet  |             |             |             |             |             |
| Ingress protection (IP) rating             | Ip20  |             |             |             |             |             |
| Working environment temperature            | -10°C~+55°C   |             |             |             |             |             |
| Working environment relative humidity (RH) | 10%~95% (No condensation)   |             |             |             |             |             |
| Storage temperature                        | -40°C~+70°C   |             |             |             |             |             |
| Storage humidity                           | 10%~100% (No condensation)  |             |             |             |             |             |
| Atmosphere                                 | No corrosive gas  |             |             |             |             |             |
| Altitude                                   | 2000m   |             |             |             |             |             |
| Pollution degree                           | Degree 2 or below: Compliant with IEC 61800-61131-2   |             |             |             |             |             |
| Surge Level                                | 2kV for power line, compliant with IEC 61000-4-4 standard   |             |             |             |             |             |
| Electrostatic discharge level              | 4kV CD and 6kV AD   |             |             |             |             |             |
| Impact resistance                          | 5~8.5Hz with an amplitude of 3.5 mm; 8.5~150Hz with an acceleration of 10 m/s <sup>2</sup> ; tested on the X, Y, and Z axes for 10 cycles |             |             |             |             |             |
| <b>Dimensions and weight</b>               |   |             |             |             |             |             |
| Weight (kg)                                | Product weight: 1.41; Packaging weight: 1.59  |             |             |             |             |             |
| Dimensions W×H×D (mm)                      | Product dimensions: 60×195×158.3; Packaging dimensions: 108×255×198   |             |             |             |             |             |

## TP2000 Product List

| Ordering code | Model       | Description  | Dimensions W x H x D (mm) |
|---------------|-------------|--|---------------------------|
| 11015-00043   | TP2321-1016 | IPC; 1 × EtherCAT master station; 16 axes; 64GB flash storage; 8GB memory; Linux   | 60×195×158.3              |
| 11015-00042   | TP2321-1032 | IPC; 1 × EtherCAT master station; 32 axes; 64GB flash storage; 8GB memory; Linux   | 60×195×158.3              |
| 11015-00045   | TP2422-1048 | IPC; 2 × EtherCAT master station; 48 axes; 128GB flash storage; 8GB memory; Linux  | 60×195×158.3              |
| 11015-00032   | TP2422-1064 | IPC; 2 × EtherCAT master station; 64 axes; 128GB flash storage; 8GB memory; Linux  | 60×195×158.3              |
| 11015-00044   | TP2422-1096 | IPC; 2 × EtherCAT master station; 96 axes; 128GB flash storage; 8GB memory; Linux  | 60×195×158.3              |
| 11015-00046   | TP2422-1128 | IPC; 2 × EtherCAT master station; 128 axes; 128GB flash storage; 8GB memory; Linux | 60×195×158.3              |

# I/O system

Hundred-megabit rate compatible with various international communication networks



## Flex series new generation distributed I/O system

INVT Flex series I/O system is a flexible, reliable, and efficient signal transmission system. The system is able to access to multiple standard communication networks, and equipped with rich signal modules to facilitate the deployment of personalized solutions while saving cabinet space, helping you develop more competitive personalized solutions.

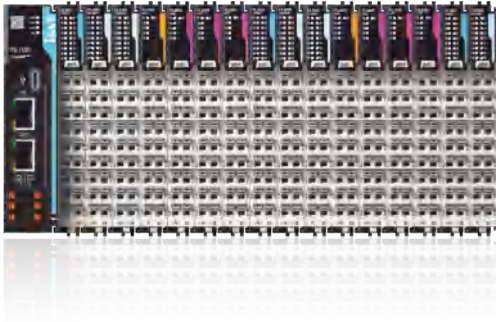

### Flexible

Rich communication couplers and I/O modules enable the exible design of control systems.



### Efficient

Fully upgraded F-BUS bus with a 100-megabit communication rate creates a high real-time communication system.



### Reliable

Tight connection using the gold plating process ensures stable and reliable signal transmission.



### Compact

Ultra-thin design significantly saves cabinet space and helps the equipment layout miniaturization.

## Flexible

The open Flex series I/O system adopts a modular design, supporting various bus network, and is equipped with rich signal modules to create personalized solutions. By importing the device description le to a third-party host controller, the module conguration can be achieved without specialized software conguration.

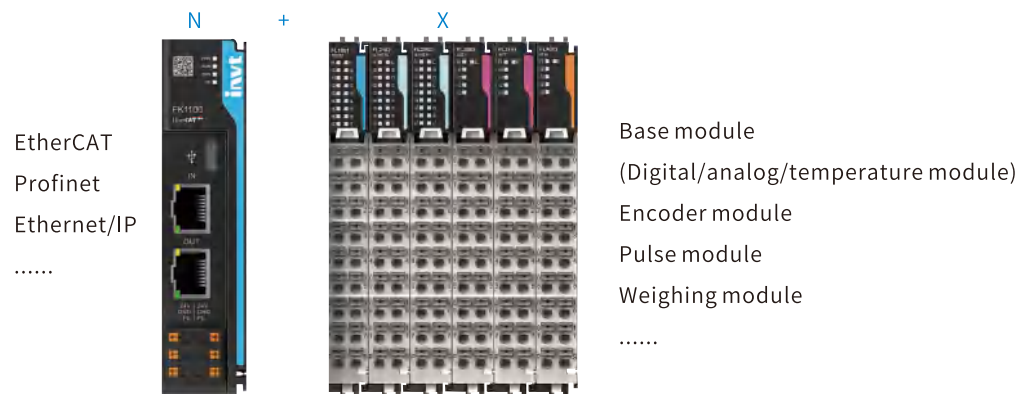

## Efficient

The system is equipped with a 100Mbps F-BUS backplane bus, with a response of I/O refresh in microseconds, achieving high-speed information exchange.

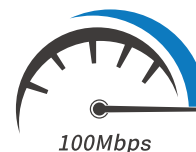

Product positioning

Spring-loaded connection technology and 5u" gold plating process keep the connectors away from various types of corrosion and ensure a long service life of connectors.



The entire series adopts three-resistance coating to prevent dust, moisture, and salt spray, meeting a wider range of operating conditions and extending service life.



Reliable grounding, further enhancing anti-interference capability.

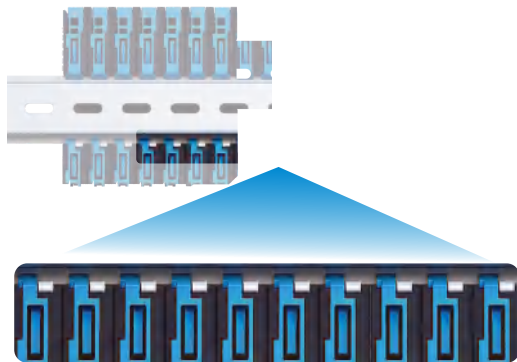

Capable of operating in -25~55°C and at an altitude of 3000m, fearless of freezing weather.



Compact

12mm ultra-thin design, saving 64% of the cabinet space, achieving miniaturization of the cabinet.



## Easy installation

The wiring diagram is printed on the module so the wiring can be completed without referencing a user manual. By scanning the QR code on the front, you can obtain an electronic version of the user manual for more information.



## Tool-free quick connection

PUSH IN connection technology enables easy installation without any tools, with a 70% improvement in wiring efficiency compared to screw terminals, effectively reducing installation time while ensuring good reliability.

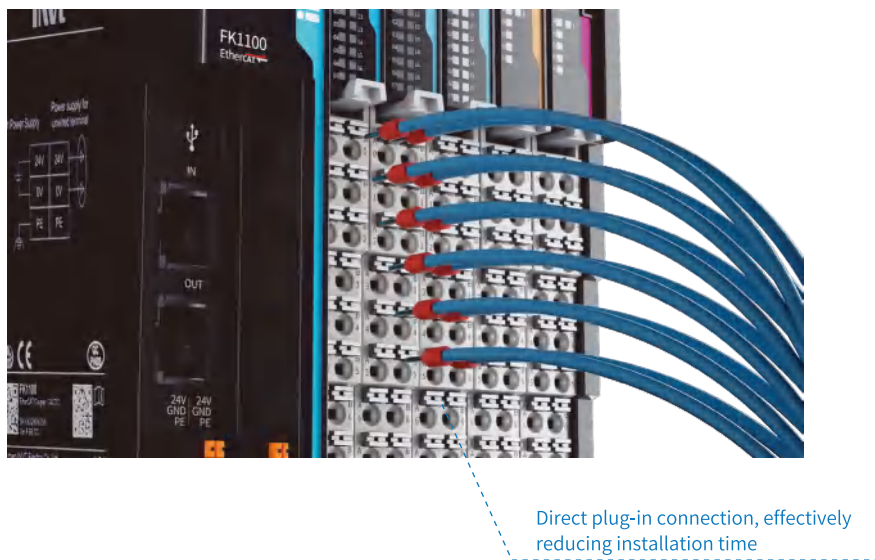

## Clear identification

▣ Different modules are distinguished by color blocks and auxiliary codes, making identification and positioning more accurate and convenient.

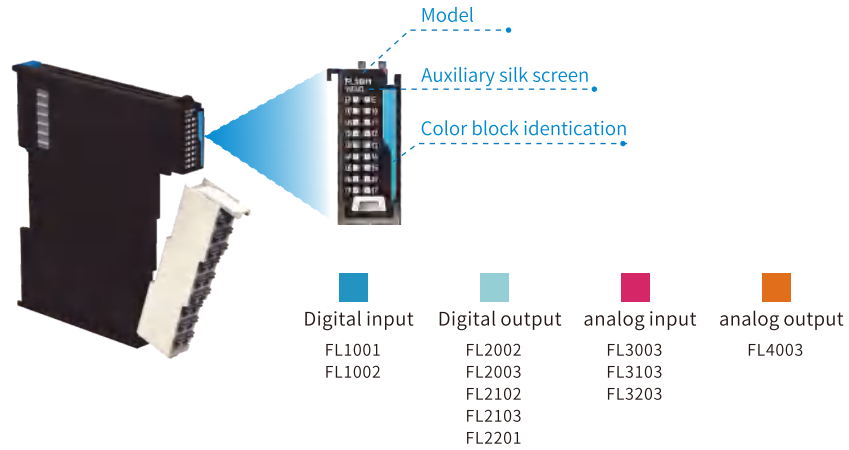

## Channel-level diagnosis

▣ Each channel has a status indicator light, and each module can independently display its working status. The operating status and fault information are clear at a glance.

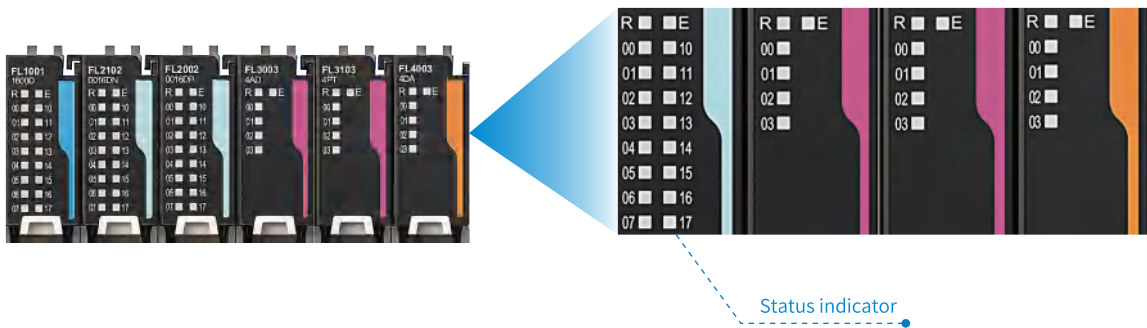

## Easy to maintain

▣ Longitudinal sliding connection allows terminal assembly and disassembly without moving the left and right modules. Adopting a two-section modular design, the wiring terminals can be disassembled separately without repeated wiring.

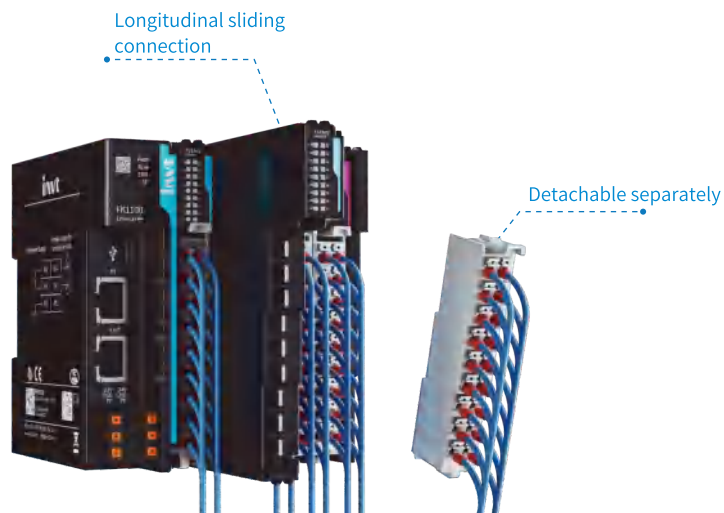

• Communication coupler (EtherCAT)

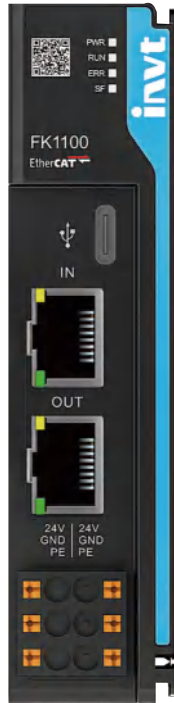

| Item                | Specifications  |  |   |  |
|---------------------|---|--|---|--|
| Ordering code       | 11016-00005   |  |   |  |
| Model               | FK1100  |  |   |  |
| Product type        | EtherCAT communication coupler  |  |   |  |
| Power supply        | Rated voltage   | 24VDC (-15%~ +20%)   |   |  |
|                     | Power consumption of module   | <10W   |   |  |
|                     | Isolation   | No isolation   |   |  |
|                     | Power supply protection   | Protection against reverse connection, overcurrent, and surges   |   |  |
| Interface           | USB2.0  | ×1, for module upgrade   |   |  |
|                     | RJ45  | ×2, EtherCAT IN&OUT  |   |  |
|                     | EtherCAT slave  | Synchronization method   | Distributed clocks or input and output synchronization  |  |
|                     |   | Physical layer   | 100BASE-TX  |  |
|                     |   | Baud rate  | 100Mbit/s   |  |
|                     |   | Output distance  | Less than 100m between two nodes  |  |
|                     |   | Transmission mode  | Full duplex   |  |
|                     |   | Topology structure   | Linear, star-shape, tree-shape  |  |
|                     |   | Slave address range  | Assigned by the system  |  |
|                     |   | Quantity of input PDO  | Up to 768 bytes   |  |
|                     |   | Quantity of output PDO   | Up to 768 bytes   |  |
|                     |   | Input mailbox size   | Up to 128 bytes   |  |
|                     | Output mailbox size   | Up to 128 bytes  |   |  |
|                     | Expansion bus   | Number of I/O expansions   | 16, internal bus. The coupler can automatically identify the I/O type and quantity on the backplane |  |
| Output power supply |   | 5V/2.5A  |   |  |
| Certification       | CE, RoHS  |  |   |  |
| Environment         | IP rating   | IP20   |   |  |
|                     | Working temperature   | -20°C~55°C   |   |  |
|                     | Working humidity  | 10%~95%RH (no condensation)  |   |  |
|                     | Air   | No corrosive gas   |   |  |
|                     | Storage temperature   | -40°C~70°C (RH<90%RH, no condensation)   |   |  |
|                     | Altitude  | Lower than 3000m   |   |  |
|                     | Pollution degree  | Degree 2, compliant with IEC61131-2  |   |  |
|                     | Anti-interference   | 2kV power cable compliant with IEC61000-4-4  |   |  |
|                     | EMC antiinterference level  | Zone B, IEC61131-2 (General industrial environment)  |   |  |
|                     | Vibration resistant   | IEC60068-2-6<br>5Hz~8.4Hz, vibration amplitude of 3.5mm, 8.4Hz~150Hz, acceleration 9.8m/s <sup>2</sup> , 100 minutes for each in X, Y, and Z directions (10 times, 10 minutes each time, a total of 100 minutes) |   |  |
| Impact resistance   | IEC60068-2-27, 9.8m/s <sup>2</sup> , 11ms, X/Y/Z, 3 times for each of 3 axes and 6 directions |  |   |  |
| Installation method | 35mm standard rail  |  |   |  |
| Weight              | Net: 0.25(Kg)   | Gross: 0.28(Kg)  |   |  |
| Dimensions W×H×D    | Product dimension: 25×105×96(mm)  |  |   |  |
|                     | Package dimension: 29×109×100(mm)   |  |   |  |

● Communication coupler (Profinet)

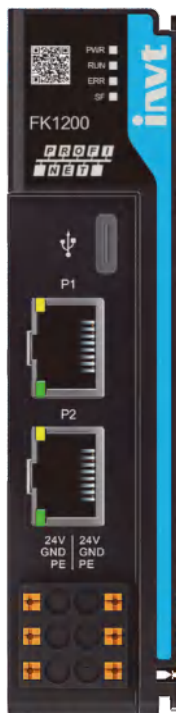

| Item                       | Specifications                                      |  |   |
|----------------------------|---|--|---|
| Ordering code              | 11016-00012   |  |   |
| Model                      | FK1200  |  |   |
| Product type               | PROFINET communication coupler                      |  |   |
| Power supply               | Rated voltage                                       | 24VDC (-15% ~ +20%)  |   |
|                            | Power consumption of module                         | <10W   |   |
|                            | Power supply protection                             | Protection against reverse connection, overcurrent, and surges   |   |
| Interface                  | Isolation   | No isolation   |   |
|                            | USB2.0  | ×1, for module upgrade   |   |
|                            |   | RJ45   | ×2, Profinet P1&P2                                    |
|                            | Profinet  | Physical layer   | 100BASE-TX  |
|                            |   | Baud rate  | 100Mbit/s   |
|                            |   | Output distance  | Less than 100m between two nodes                      |
|                            |   | Transmission mode  | Full duplex   |
|                            |   | Topology structure   | Linear, star-shape, tree-shape                        |
|                            |   | Communication protocol   | Profinet IO Device                                    |
|                            |   | Communication mode   | RT  |
|                            |   | Communication period   | Min. 1ms  |
|                            |   | Process data zone  | Input max. 1440 bytes, output max. 1440bytes; IM0-IM3 |
|                            |   | Pronet switch function   | Supports networking function                          |
|                            | Ethernet service                                    | Supports TCP/IP, SNMP, LLDP, ping, arp   |   |
|                            | Port diagnosis                                      | Supported  |   |
| Port disabling             | Supported   |  |   |
| Factory settings reset     | Supported   |  |   |
| Expansion bus              | Number of I/O expansions                            | 16, internal bus. The coupler can automatically identify the I/O type and quantity on the backplane  |   |
|                            | Output power supply                                 | 5V/2.5A  |   |
| Certification              | CE, RoHS  |  |   |
| Environment                | IP rating   | IP20   |   |
|                            | Working temperature                                 | -25°C~55°C   |   |
|                            | Working humidity                                    | 10%~95%RH (no condensation)  |   |
|                            | Air   | No corrosive gas   |   |
|                            | Storage temperature                                 | -40°C~70°C (RH<90%RH, no condensation)   |   |
|                            | Altitude  | Lower than 3000m   |   |
|                            | Pollution degree                                    | Degree 2, compliant with IEC61131-2  |   |
|                            | Anti-interference                                   | 2kV power cable compliant with IEC61000-4-4  |   |
| EMC antiinterference level | Zone B, IEC61131-2 (General industrial environment) |  |   |
|                            | Vibration resistant                                 | IEC60068-2-6<br>5Hz~8.4Hz, vibration amplitude of 3.5mm, 8.4Hz~150Hz, acceleration 9.8m/s <sup>2</sup> , 100 minutes for each in X, Y, and Z directions (10 times, 10 minutes each time, a total of 100 minutes) |   |
|                            | Impact resistance                                   | IEC60068-2-27, 9.8m/s <sup>2</sup> , 11ms, X/Y/Z, 3 times for each of 3 axes and 6 directions  |   |
| Installation method        | 35mm standard rail                                  |  |   |
| Weight                     | Net: 0.25(Kg)                                       | Gross: 0.28(Kg)  |   |
| Dimensions W×H×D           | Product dimension: 25×105×96(mm)                    |  |   |
|                            | Package dimension: 29×109×100(mm)                   |  |   |

Small PLC

Medium PLC

X86 Controller

I/O System

HMI

Industrial Internet

• Communication coupler (EtherNet/IP)

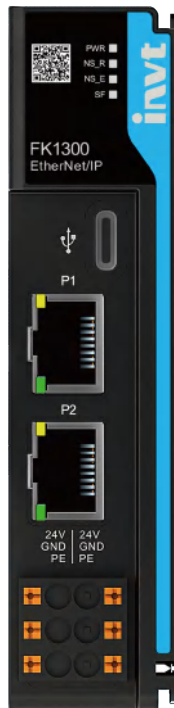

| Item                | Specifications   |   |   |  |
|---------------------|--|---|---|--|
| Ordering code       | 11016-00018  |   |   |  |
| Model               | FK1300   |   |   |  |
| Product type        | EtherNet/IP communication coupler  |   |   |  |
| Power supply        | Rated voltage  | 24VDC (-15%~ +20%)  |   |  |
|                     | Power consumption of module  | <10W  |   |  |
|                     | Isolation  | No isolation  |   |  |
|                     | Power supply protection  | Protection against reverse connection, overcurrent, and surges    |   |  |
| Interface           | USB2.0   | ×1, used for module upgrade                                       |   |  |
|                     | RJ45   | ×2, EtherNet/IP P1&P2   |   |  |
|                     | EtherNet/IP  | Physical layer  | 100BASE-TX  |  |
|                     |  | Baud rate   | 100Mbit/s   |  |
|                     |  | Output distance   | Less than 100m between two nodes                                    |  |
|                     |  | Transmission mode   | Full duplex   |  |
|                     |  | Topology structure  | Linear, star, or tree   |  |
|                     |  | Communication protocol  | EtherNet/IP   |  |
|                     |  | Max input length  | 504 bytes   |  |
|                     |  | Max output length   | 504 bytes   |  |
|                     |  | Max number of explicit message connections                        | 6   |  |
|                     |  | Max number of implicit message connections                        | 3   |  |
|                     |  | Max number of CIP connections                                     | 6   |  |
|                     | Min. request packet interval (RPI)   | 1ms   |   |  |
|                     | Alarm/Diagnosis status information   | Supporting the upload of function codes from the local to the PLC |   |  |
|                     | Expansion bus  | Number of I/O expansions  | Up to 16, which depends on the actual power consumption calculation |  |
|                     |  | Output power supply   | 5V/2.5A   |  |
| Certification       | CE, RoHS   |   |   |  |
| Environment         | IP rating  | IP20  |   |  |
|                     | Working temperature  | -20°C~55°C  |   |  |
|                     | Working humidity   | 10%~95%RH (no condensation)                                       |   |  |
|                     | Air  | No corrosive gas  |   |  |
|                     | Storage temperature  | -40°C~70°C (RH<90%RH, no condensation)                            |   |  |
|                     | Altitude   | Lower than 3000m  |   |  |
|                     | Pollution degree   | Degree 2, compliant with IEC61131-2                               |   |  |
|                     | Anti-interference  | 2kV power cable compliant with IEC61000-4-4                       |   |  |
|                     | EMC antiinterference level   | Zone B, IEC61131-2 (General industrial environment)               |   |  |
| Vibration resistant | IEC60068-2-6   |   |   |  |
|                     | 5Hz~8.4Hz, vibration amplitude of 3.5mm, 8.4Hz~150Hz, acceleration 9.8m/s <sup>2</sup> , 100 minutes for each in X, Y, and Z directions (10 times, 10 minutes each time, a total of 100 minutes) |   |   |  |
| Impact resistance   | IEC60068-2-27, 9.8m/s <sup>2</sup> , 11ms, X/Y/Z, 3 times for each of 3 axes and 6 directions  |   |   |  |
| Installation method | 35mm standard rail   |   |   |  |
| Weight              | Net: 0.25(Kg)  | Gross: 0.28(Kg)   |   |  |
| Dimensions W×H×D    | Product dimension: 25×105×96(mm)   |   |   |  |
|                     | Package dimension: 29×109×100(mm)  |   |   |  |

● Communication coupler (Modbus TCP)



| Item                          | Specifications  |  |                                |
|-------------------------------|---|--|--------------------------------|
| Ordering code                 | 11016-00029   |  |                                |
| Model                         | FK1400  |  |                                |
| Product type                  | Modbus TCP communication coupler  |  |                                |
| Power supply                  | Rated voltage   | 24VDC (-15%~ +20%)   |                                |
|                               | Power consumption of module   | <10W   |                                |
|                               | Isolation   | No isolation   |                                |
|                               | Power supply protection   | Protection against reverse connection, overcurrent, and surges                                 |                                |
| Interface                     | USB2.0  | ×1, used for module upgrade  |                                |
|                               | RJ45  | ×2, Modbus TCP   |                                |
|                               | Modbus TCP server (slave)   | Max. number of client connections  | 5                              |
|                               |   | TCP keepalive timer  | Supported                      |
|                               |   | Watchdog setting   | Supported (on by default, 30s) |
|                               |   | Supported function codes   | 01/02/03/04/05/06/15/16/23     |
|                               |   | IP address setting   | Using the Ttools-IO tool       |
|                               |   | Diagnostic function  | Supported                      |
|                               |   | Physical layer   | 100BASE-TX                     |
|                               |   | Communication rate   | 10M/100Mbps, adaptive          |
|                               |   | Communication method   | Full duplex                    |
|                               |   | Topology structure   | Linear, star, tree             |
|                               | Transmission medium   | Category-5 or higher network cables  |                                |
|                               | Transmission distance   | Max. segment length: 100m  |                                |
|                               | Alarm/Diagnosis status information  | Supporting the upload of function codes from the local to the PLC                              |                                |
| Expansion bus                 | Scalable I/O count  | Up to 32, must be used with power feed modules. The actual number depends on power consumption |                                |
|                               | Output power supply   | 5V/2.5A(12.5W)   |                                |
| Certification                 | CE, RoHS  |  |                                |
| Environment                   | IP rating   | IP20   |                                |
|                               | Working temperature   | -20°C~55°C   |                                |
|                               | Working humidity  | 10%~95%RH (no condensation)  |                                |
|                               | Air   | No corrosive gas   |                                |
|                               | Storage temperature   | -40°C~70°C (RH<90%RH, no condensation)   |                                |
|                               | Altitude  | Below 3000m  |                                |
|                               | Pollution degree  | Degree 2 or lower, compliant with IEC61131-2   |                                |
|                               | Immunity standard   | 2kV power cable, compliant with IEC61000-4-4   |                                |
|                               | EMC standard  | Zone B, IEC61131-2 (general industrial environment)  |                                |
| Vibration resistance standard | IEC60068-2-6  |  |                                |
| Impact test                   | IEC60068-2-27, 9.8m/s <sup>2</sup> , 11ms, X/Y/Z, 3 axes in 6 directions repeated 3 times |  |                                |
| Installation method           | 35mm standard rail  |  |                                |
| Weight                        | Net: 0.25(Kg) Gross: 0.28(Kg)   |  |                                |
| Dimensions W×H×D              | Product dimension: 25×105×96(mm)  |  |                                |
|                               | Package dimension: 29×109×100(mm)   |  |                                |

Small PLC

Medium PLC

X86 Controller

I/O System

HMI

Industrial Internet

• Digital input

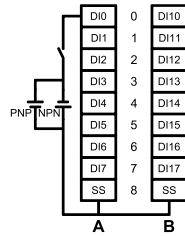

| Model                    | FL1001   |
|--------------------------|--|
| Ordering code            | 11016-00004  |
| Product type             | Digital input, supporting source type/sink type  |
| Power loss               | 0.71W  |
| Number of channels       | 16   |
| Input type               | Source/sink  |
| Input voltage            | DC24V±10%  |
| Input current            | 7mA  |
| Max. input frequency     | 500Hz (duty ratio: 40%-60%)  |
| Port filter time         | Setting range: 1-65535 (default 1000), unit: 10µs; 1000 indicates 10ms. Able to set two groups of lter parameter. Every eight channels use a group of lter parameter |
| Signal of logic 1        | ≥15V DC  |
| Signal of logic 0        | ≤5V DC   |
| OFF-ON response time     | 100µs  |
| ON-OFF response time     | 100µs  |
| Isolation method         | Optocoupler  |
| Input frequency decrease | Derate by 75% when operating at 55°C (with no more than 12 input points that are on at the same time), or by 10°C when all input points are on                       |
| Weight                   | Net: 0.15(Kg) Gross: 0.18(Kg)  |
| Dimensions (W×H×D)       | Product dimension: 12.5×105×96mm<br>Package dimension: 17.5×109×100mm  |

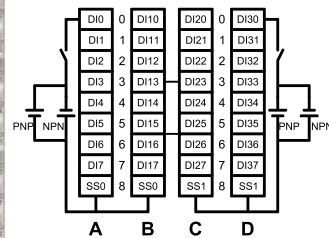

| Model                    | FL1002  |
|--------------------------|---|
| Ordering code            | 11016-00016   |
| Product type             | Digital input, supporting source type/sink type   |
| Power loss               | 0.73W   |
| Number of channels       | 32  |
| Input type               | Source/sink   |
| Input voltage            | DC24V±10%   |
| Input current            | 7mA   |
| Max. input frequency     | 500Hz (duty ratio: 40%-60%)   |
| Port filter time         | Setting range: 1-65535 (default 1000), unit: 10µs; 1000 indicates 10ms. Able to set two groups of lter parameter. Every eight channels use a group of lter parameter. |
| Signal of logic 1        | ≥15V DC   |
| Signal of logic 0        | ≤5V DC  |
| OFF-ON response time     | 100µs   |
| ON-OFF response time     | 100µs   |
| Isolation method         | Optocoupler   |
| Input frequency decrease | Derate by 75% when operating at 55°C (with no more than 12 input points that are on at the same time), or by 10°C when all input points are on                        |
| Weight                   | Net: 0.30(Kg) Gross: 0.33(Kg)   |
| Dimensions (W×H×D)       | Product dimension: 25×105×96mm<br>Package dimension: 29×109×100mm   |

● Digital output (source type)

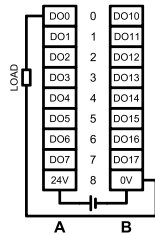

| Model   | FL2002   |
|---|--|
| Ordering code                                       | 11016-00006  |
| Product type  | Digital output, transistor source type output, active high   |
| Power loss  | 0.77W  |
| Number of channels                                  | 16   |
| External power                                      | DC24V (-15%~+20%)  |
| Output voltage                                      | 24V±10%  |
| Max. output frequency                               | 1kHz   |
| Max. load   | Resistive load: 0.5A/point, 2A/module<br>Inductive load: 7.2W/point, 12W/module<br>Illumination load: 5W/point, 18W/module |
| Leakage current/point                               | <10uA  |
| OFF-ON response time                                | 100µs  |
| ON-OFF response time                                | 100µs  |
| Protection against overheat/overcurrent/overvoltage | Supported  |
| Exception check of external power                   | Supported  |
| Isolation method                                    | Magnetic   |
| Short-circuit protection output                     | Yes  |
| Weight  | Net: 0.15(Kg) Gross: 0.18(Kg)  |
| Dimensions (W×H×D)                                  | Product dimension: 12.5×105×96mm<br>Package dimension: 17.5×109×100mm  |

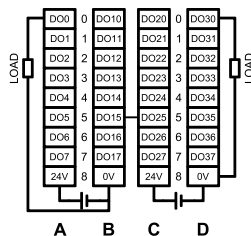

| Model   | FL2003   |
|---|--|
| Ordering code                                       | 11016-00013  |
| Product type  | Digital output, transistor source type output, active high   |
| Power loss  | 0.78W  |
| Number of channels                                  | 32   |
| External power                                      | DC24V (-15%~+20%)  |
| Output voltage                                      | 24V±10%  |
| Max. output frequency                               | 1kHz   |
| Max. load   | Resistive load: 0.5A/point, 2A/module<br>Inductive load: 7.2W/point, 12W/module<br>Illumination load: 5W/point, 18W/module |
| Leakage current/point                               | <10uA  |
| OFF-ON response time                                | 100µs  |
| ON-OFF response time                                | 100µs  |
| Protection against overheat/overcurrent/overvoltage | Supported  |
| Exception check of external power                   | Supported  |
| Isolation method                                    | Optocoupler isolation  |
| Short-circuit protection output                     | Yes  |
| Weight  | Net: 0.30(Kg) Gross: 0.33(Kg)  |
| Dimensions (W×H×D)                                  | Product dimension: 25×105×96mm<br>Package dimension: 29×109×100mm  |

● Digital output (sink type)

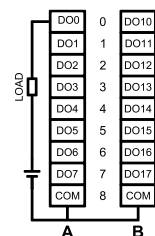

| Model   | FL2102   |
|---|--|
| Ordering code                                       | 11016-00003  |
| Product type  | Digital output, transistor sink type output, active low  |
| Power loss  | 1.04W  |
| Number of channels                                  | 16   |
| External power                                      | DC24V (-15%~+20%)  |
| Output voltage                                      | 24V±10%  |
| Max. output frequency                               | 1kHz (duty ratio: 40%~60%)   |
| Max. load   | Resistive load: 0.5A/point, 4A/module<br>Inductive load: 7.2W/point, 24W/module<br>Illumination load: 5W/point, 18W/module |
| Leakage current/point                               | <10uA  |
| OFF-ON response time                                | 100µs  |
| ON-OFF response time                                | 100µs  |
| Protection against overheat/overcurrent/overvoltage | Supported  |
| Exception check of external power                   | Supported  |
| Isolation method                                    | Magnetic   |
| Short-circuit protection output                     | Yes  |
| Weight  | Net: 0.15(Kg) Gross: 0.18(Kg)  |
| Dimensions (W×H×D)                                  | Product dimension: 12.5×105×96mm<br>Package dimension: 17.5×109×100mm  |

● Digital output (sink type)

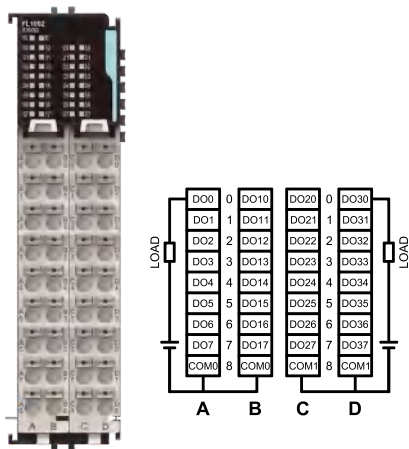

| Model   | FL2103   |
|---|--|
| Ordering code                                       | 11016-00017  |
| Product type  | Digital output, transistor sink type output, active low  |
| Power loss  | 1.46W  |
| Number of channels                                  | 32   |
| External power                                      | DC24V (-15%~+20%)  |
| Output voltage                                      | DC24V±10%  |
| Max. output frequency                               | 1kHz (duty ratio: 40%~60%)   |
| Max. load   | Resistive load: 0.5A/point, 4A/module<br>Inductive load: 7.2W/point, 24W/module<br>Illumination load: 5W/point, 18W/module |
| Leakage current/point                               | <10uA  |
| OFF-ON response time                                | 100μs  |
| ON-OFF response time                                | 100μs  |
| Protection against overheat/overcurrent/overvoltage | Supported  |
| Exception check of external power                   | Supported  |
| Isolation method                                    | Magnetic   |
| Short-circuit protection output                     | Yes  |
| Weight  | Net: 0.15(Kg) Gross: 0.18(Kg)  |
| Dimensions (W×H×D)                                  | Product dimension: 25×105×96mm<br>Package dimension: 29×109×100mm  |

● Digital input & output (source type)

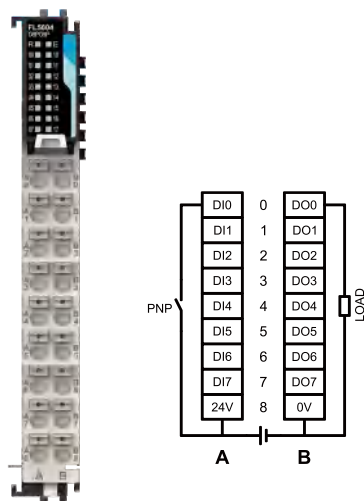

| Model   | FL5004  |
|---|---|
| Ordering code                                       | 11016-00045   |
| Product type  | Digital input and output  |
| Power loss, typ.                                    | 0.78W   |
| Number of input channels                            | 8   |
| Input type  | Source  |
| Input voltage                                       | DC24V±10%   |
| Input current                                       | 5.2mA   |
| Port filter time                                    | Setting range: 1~65535 (default 1000), unit: 10μs;<br>1000 indicates 10ms. Eight channels use a group of filter parameter                     |
| Signal of logic 1                                   | ≥15V DC   |
| Signal of logic 0                                   | ≤5V DC  |
| Isolation method                                    | Optocoupler   |
| Input frequency decrease                            | Derate by 75% when operating at 55°C (with no more than 4 input points that are on at the same time), or by 10°C when all input points are on |
| Number of output channels                           | 8   |
| Output type   | Transistor, sink type, active high  |
| External power                                      | DC24V(-15%~+20%)  |
| Output voltage                                      | 24V±10%   |
| Max. load   | Resistive load: 0.5A/point, 2A/module<br>Inductive load: 7.2W/point, 12W/module<br>Illumination load: 5W/point, 9W/module                     |
| Leakage current/point                               | <10uA   |
| Protection against overheat/overcurrent/overvoltage | Supported   |
| Exception check of external power                   | Supported   |
| Isolation method                                    | Capacitive isolation  |
| Short-circuit protection output                     | Supported   |
| OFF-ON  | 300μs   |
| ON-OFF  | 300μs   |
| Weight  | Net: 0.15Kg Gross: 0.18Kg   |
| Dimensions (W×H×D)                                  | Product dimension: 12.5×105×96mm<br>Package dimension: 17.5×109×100mm   |

• Digital input & output (sink type)

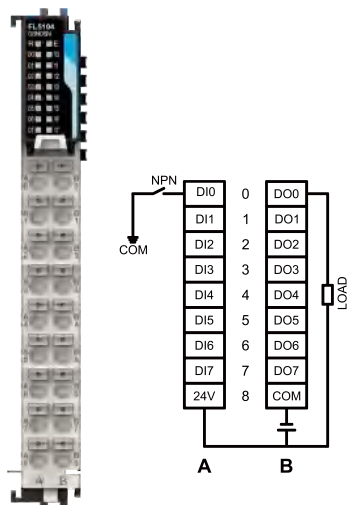

| Model   | FL5104  |
|---|---|
| Ordering code                                       | 11016-00044   |
| Product type  | Digital input and output  |
| Power loss, typ.                                    | 0.78W   |
| Number of input channels                            | 8   |
| Input type  | Sink  |
| Input voltage                                       | DC24V±10%   |
| Input current                                       | 5.2mA   |
| Port filter time                                    | Setting range: 1-65535 (default 1000), unit: 10μs; 1000 indicates 10ms. Eight channels use a group of filter parameter                        |
| Signal of logic 1                                   | ≥15V DC   |
| Signal of logic 0                                   | ≤5V DC  |
| Isolation method                                    | Optocoupler   |
| Input frequency decrease                            | Derate by 75% when operating at 55°C (with no more than 4 input points that are on at the same time), or by 10°C when all input points are on |
| Number of output channels                           | 8   |
| Output type   | Transistor, sink type, active low   |
| External power                                      | DC24V(-15%~+20%)  |
| Output voltage                                      | 24V±10%   |
| Max. load   | Resistive load:0.5A/point, 2A/module<br>Inductive load: 7.2W/point, 12W/module<br>Illumination load:5W/point, 9W/module                       |
| Leakage current/point                               | <10uA   |
| Protection against overheat/overcurrent/overvoltage | Supported   |
| Exception check of external power                   | Supported   |
| Isolation method                                    | Capacitive isolation  |
| Short-circuit protection output                     | Supported   |
| OFF-ON  | 300μs   |
| ON-OFF  | 300μs   |
| Weight  | Net: 0.15Kg Gross:0.18Kg  |
| Dimensions (W×H×D)                                  | Product dimension: 12.5×105×96mm<br>Package dimension:17.5×109×100mm  |

● Digital input & output (source type)

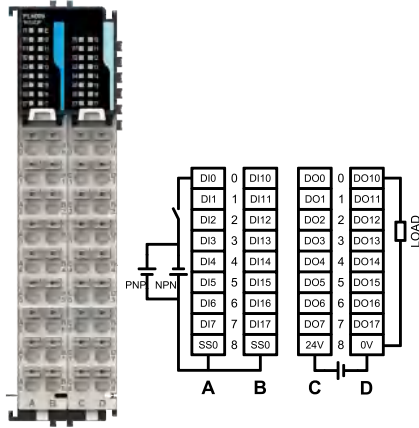

| Model   | FL5005  |
|---|---|
| Ordering code                                       | 11016-00015   |
| Product type  | Digital input and output  |
| Power loss  | 0.68W   |
| Number of channels                                  | 16  |
| Input type  | Source/sink   |
| Input voltage                                       | DC24V ± 10%   |
| Input current, typ                                  | 7mA   |
| Max. input frequency                                | 500Hz (duty ratio: 40%~60%)   |
| Port filter time                                    | Setting range: 1~65535 (default 1000), unit: 10μs; 1000 indicates 10ms. Able to set two groups of lter parameter. Every eight channels use a group of lter parameter. |
| Signal of logic 1                                   | ≥15V DC   |
| Signal of logic 0                                   | ≤5V DC  |
| OFF-ON response time                                | 100μs   |
| ON-OFF response time                                | 100μs   |
| Isolation method                                    | Optocoupler   |
| Input frequency decrease                            | Derate by 75% when operating at 55°C (with no more than 12 input points that are on at the same time), or by 10°C when all input points are on                        |
| Number of output channels                           | 16  |
| Output type   | Source, active high   |
| External power                                      | DC24V (-15%~+20%)   |
| Output voltage                                      | 24V ± 10%   |
| Max. output frequency                               | 1kHz  |
| Max. load   | Resistive load: 0.5A/point; 2A/module<br>Inductive load: 7.2W/point; 12W/module<br>Illumination load: 5W/point; 18W/module  |
| Leakage current/point                               | <10uA   |
| Protection against overheat/overcurrent/overvoltage | Supported   |
| Exception check of external power                   | Supported   |
| Isolation method                                    | Magnetic  |
| Short-circuit protection output                     | Yes   |
| OFF-ON  | 100μs   |
| ON-OFF  | 100μs   |
| Weight  | Net: 0.30(Kg) Gross: 0.33(Kg)   |
| Dimensions (W×H×D)                                  | Product dimension: 25×105×96mm<br>Package dimension: 29×109×100mm   |

● Digital input & output (sink type)

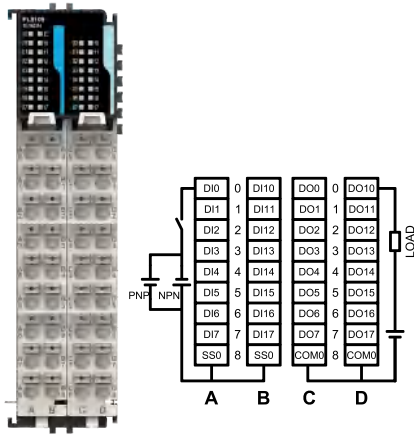

| Model   | FL5105  |
|---|---|
| Ordering code                                       | 11016-00014   |
| Product type  | Digital input and output  |
| Power loss  | 1.05W   |
| Number of channels                                  | 16  |
| Input type  | Source/sink   |
| Input voltage                                       | DC24V±10%   |
| Input current,typ                                   | 7mA   |
| Max. input frequency                                | 500Hz (duty ratio: 40%~60%)   |
| Port filter time                                    | Setting range: 1~65535 (default 1000), unit: 10μs; 1000 indicates 10ms. Able to set two groups of lter parameter. Every eight channels use a group of lter parameter. |
| Signal of logic 1                                   | ≥15V DC   |
| Signal of logic 0                                   | ≤5V DC  |
| OFF-ON response time                                | 100μs   |
| ON-OFF response time                                | 100μs   |
| Isolation method                                    | Optocoupler   |
| Input frequency decrease                            | Derate by 75% when operating at 55°C (with no more than 12 input points that are on at the same time), or by 10°C when all input points are on                        |
| Number of output channels                           | 16  |
| Output type   | sink, active low  |
| External power                                      | DC24V (-15%~+20%)   |
| Output voltage                                      | 24V±10%   |
| Max. output frequency                               | 1kHz  |
| Max. load   | Resistive load: 0.5A/point; 4A/module<br>Inductive load: 7.2W/point; 24W/module<br>Illumination load: 5W/point; 18W/module  |
| Leakage current/point                               | <10uA   |
| Protection against overheat/overcurrent/overvoltage | Supported   |
| Exception check of external power                   | Supported   |
| Isolation method                                    | Magnetic  |
| Short-circuit protection output                     | Yes   |
| OFF-ON  | 100μs   |
| ON-OFF  | 100μs   |
| Weight  | Net: 0.30(Kg) Gross: 0.33(Kg)   |
| Dimensions (W×H×D)                                  | Product dimension: 25×105×96mm<br>Package dimension: 29×109×100mm   |

● Digital output (relay)

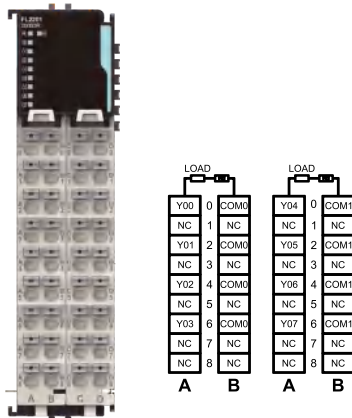

| Model                    | FL2201  |
|--------------------------|---|
| Ordering code            | 11016-00009   |
| Product type             | Digital output, relay output                                      |
| Power loss               | 1.56W   |
| Number of channels       | 8   |
| Contact type             | N.O. contact  |
| Contact load (resistive) | 3A 250VAC/30VDC   |
| Max. switching voltage   | 250VAC/125VDC@0.3A  |
| Max. switching current   | 5A  |
| Service life of relay    | Electrical: 100,000 times<br>Mechanical: 20,000,000 times         |
| OFF-ON response time     | ≤15ms   |
| ON-OFF response time     | ≤10ms   |
| Weight                   | Net: 0.30(Kg) Gross: 0.33(Kg)                                     |
| Dimensions (W×H×D)       | Product dimension: 25×105×96mm<br>Package dimension: 29×109×100mm |

• Analog input

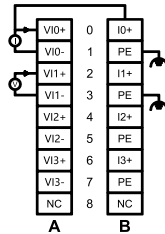

| Model                                     | FL3003  |
|---|---|
| Ordering code                             | 11016-00011   |
| Product type                              | 4 channels of analog input  |
| Power consumption                         | 0.83W   |
| Number of channels                        | 4   |
| Voltage range                             | ±5V, ±10V, +5V, +10V  |
| Current range                             | 0-20mA, 4-20mA, ±20mA   |
| Accuracy in room temperature (of 25°C)    | Voltage ±0.1%FS, current ±0.1%FS  |
| Converting speed                          | 320µs/channel   |
| Max. common-mode voltage between channels | 30VDC   |
| Disconnection detection                   | Support (only voltage)  |
| Isolation method                          | Between I/O port and power supply: isolated<br>Between channels: not isolated |
| Resolution                                | 16 bits   |
| Weight                                    | Net: 0.15(Kg) Gross: 0.18(Kg)   |
| Dimensions (W×H×D)                        | Product dimension: 12.5×105×96mm<br>Package dimension: 17.5×109×100mm         |

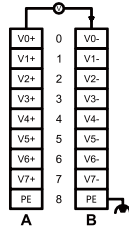

| Model                                     | FL3404   |
|---|--|
| Ordering code                             | 11016-00026  |
| Product type                              | 8-channel analog voltage input   |
| Power consumption                         | 0.81W  |
| Number of channels                        | 8  |
| Voltage range                             | ±5V, ±10V, 0~5V, 0~10V, 1~5V   |
| Input mode                                | Differential   |
| Accuracy in room temperature (of 25°C)    | ±0.15%FS   |
| Accuracy in working temperature           | ±0.3%FS  |
| Converting speed                          | 170µs/channel  |
| Voltage input limit                       | ±15VDC   |
| Max. common-mode voltage between channels | 30VDC  |
| Disconnection detection                   | Not supported  |
| Over limit detection                      | Supported  |
| Over range detection                      | Supported  |
| Isolation method                          | Isolated between I/O ports and power supplies<br>Not isolated between channels |
| Resolution                                | 16 bits  |
| Weight                                    | Net: 0.15(Kg) Gross: 0.18(Kg)  |
| Dimensions (W×H×D)                        | Product dimension: 12.5×105×96mm<br>Package dimension: 17.5×109×100mm          |

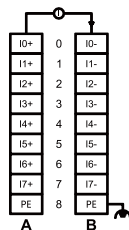

| Model                                     | FL3504   |
|---|--|
| Ordering code                             | 11016-00027  |
| Product type                              | 8-channel analog current input   |
| Power consumption                         | 0.81W  |
| Number of channels                        | 8  |
| Current range                             | 0~20mA, 4~20mA, ±20mA  |
| Input mode                                | Differential   |
| Accuracy in room temperature (of 25°C)    | ±0.15%FS   |
| Accuracy in working temperature           | ±0.3%FS  |
| Converting speed                          | 170µs/channel  |
| Current input limit                       | 30mA   |
| Max. common-mode voltage between channels | 30VDC  |
| Disconnection detection                   | Not supported  |
| Over limit detection                      | Supported  |
| Over range detection                      | Supported  |
| Isolation method                          | Isolated between I/O ports and power supplies<br>Not isolated between channels |
| Resolution                                | 16 bits  |
| Weight                                    | Net: 0.15(Kg) Gross: 0.18(Kg)  |
| Dimensions (W×H×D)                        | Product dimension: 12.5×105×96mm<br>Package dimension: 17.5×109×100mm          |

● Analog output

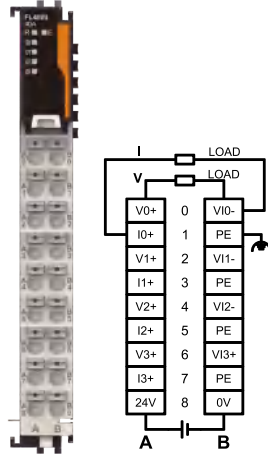

| Model                                      | FL4003  |
|--|---|
| Ordering code                              | 11016-00008   |
| Product type                               | 4 channels of analog output   |
| External power                             | 24VDC (-15%~+20%)   |
| Power consumption                          | 0.68W   |
| Number of channels                         | 4   |
| Voltage range                              | ±5V, ±10V, 0~5V, 0~10V  |
| Current range                              | 0~20mA, 4~20mA  |
| Accuracy in room temperature (of 25°C)     | Voltage ±0.1%FS, current ±0.1%FS  |
| Converting speed                           | 40µs/channel  |
| Min. load resistance during voltage output | 1kΩ   |
| Max. load resistance during current output | 600Ω  |
| Disconnection detection                    | Support (only current)  |
| Isolation method                           | Between I/O port and power supply: isolated<br>Between channels: not isolated |
| Resolution                                 | 16 bits   |
| Weight                                     | Net: 0.15(Kg) Gross: 0.18(Kg)   |
| Dimensions (W×H×D)                         | Product dimension: 12.5×105×96mm<br>Package dimension: 17.5×109×100mm         |

● Temperature measuring (thermistor)

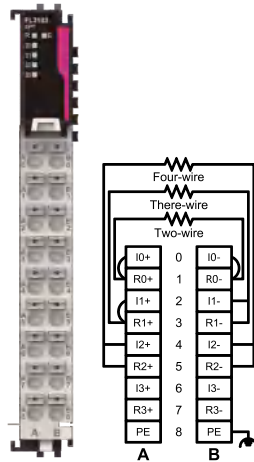

| Model                                  | FL3103  |
|--|---|
| Ordering code                          | 11016-00007   |
| Product type                           | 4 channels of thermistor input  |
| Power consumption                      | 0.88W   |
| Number of channels                     | 4   |
| Wiring method                          | Two-, three-, or four-wire  |
| Supported thermal resistors            | PT100, PT500, PT1000, CU100   |
| Sensitivity                            | 0.0625°C/0.0625°F   |
| SamplePeriod                           | 240ms/channel (typical value)   |
| Accuracy in room temperature (of 25°C) | ±0.1%FS   |
| Accuracy in working temperature        | ±1%FS   |
| Filter time                            | Adjustable  |
| Accuracy in working temperature        | ±0.3%FS   |
| Isolation method                       | Between I/O port and power supply: isolated<br>Between channels: not isolated |
| Weight                                 | Net: 0.15(Kg) Gross: 0.18(Kg)   |
| Dimensions (W×H×D)                     | Product dimension: 12.5×105×96mm<br>Package dimension: 17.5×109×100mm         |

● Temperature measuring (thermocouple)

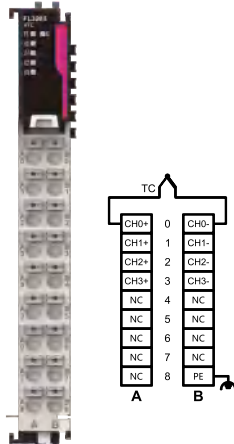

| Model                                  | FL3203  |
|--|---|
| Ordering code                          | 11016-00010   |
| Product type                           | 4 channels of thermocouple input  |
| Power loss                             | 0.78W   |
| Number of channels                     | 4   |
| Supported thermocouples                | Types B, E, J, K, N, R, S, and T  |
| Sensitivity                            | 0.0625°C/0.0625°F   |
| SamplePeriod                           | 360ms/channel   |
| Accuracy in room temperature (of 25°C) | ±0.1%FS+cold junction compensation error                                      |
| Accuracy in working temperature        | ±0.3%FS+cold junction compensation error                                      |
| Cold junction compensation method      | Internal  |
| Disconnection detection                | Supported   |
| Isolation method                       | Between I/O port and power supply: isolated<br>Between channels: not isolated |
| Weight                                 | Net: 0.15(Kg) Gross: 0.18(Kg)   |
| Dimensions (W×H×D)                     | Product dimension: 12.5×105×96mm<br>Package dimension: 17.5×109×100mm         |

● Counting and position measurement

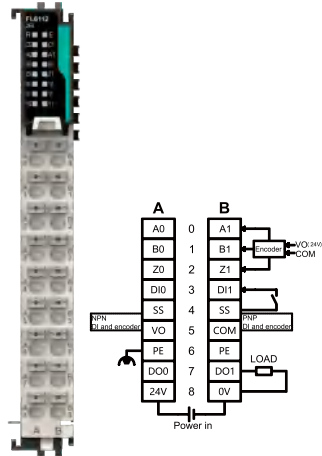

| Model                                   | FL6112  |
|---|---|
| Ordering code                           | 11016-00019   |
| Product category                        | Incremental encoder module  |
| Power consumption                       | 0.68W   |
| Number of channels                      | 2   |
| Encoder voltage                         | 24VDC±15%   |
| Counting range                          | -2147483648~2147483647  |
| Pulse mode                              | AB-phase quadrature pulse/Pulse + direction                           |
| Pulse frequency                         | 200KHz  |
| Frequency multiplication mode           | X1/X2/X4  |
| Resolution                              | 1-65535 ppr (number of pulses per revolution)                         |
| Counter preset                          | Software preset   |
| Z-pulse calibration                     | Supported by default for Z signa                                      |
| Counter filter                          | 0.1~65535*0.1µs per channel   |
| Number of DIs                           | 1 per channel   |
| DI voltage                              | 24VDC   |
| DI edge selection                       | Rising edge/Falling edge/Rising or falling edge                       |
| DI type                                 | Source or sink  |
| DI filter time setting                  | 0.1~65535*0.1µs per channel   |
| DI function                             | Latch and reset   |
| Latched value                           | Total latched values and latch completion flags                       |
| ON/OFF response time                    | µs level  |
| Number of DOs                           | 1 per channel   |
| DO voltage                              | 24V   |
| DO type                                 | Sink type, max. current 0.16A   |
| DO function                             | High-speed comparison output  |
| Measurement variable                    | Frequency/Speed   |
| Update time of the measurement function | 20/100/500/1000ms   |
| Gating function                         | Software gate   |
| Weight                                  | Net: 0.15(Kg) Gross: 0.18(Kg)   |
| Dimensions (W×H×D)                      | Product dimension: 12.5×105×96mm<br>Package dimension: 17.5×109×100mm |

● Counting and position measurement

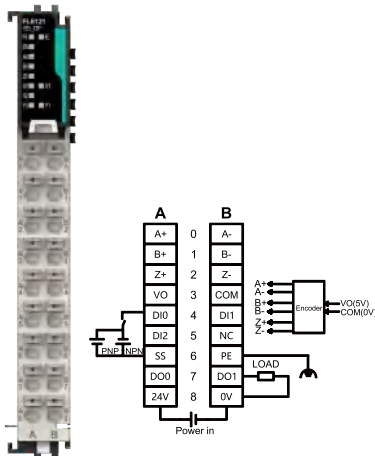

| Model                                   | FL6121  |
|---|---|
| Ordering code                           | 11016-00021   |
| Product category                        | Incremental encoder module  |
| Power consumption                       | 0.68W   |
| Number of channels                      | 2   |
| Encoder voltage                         | 5VDC  |
| Encoder signal type                     | RS422 electrical level standards, differential input                  |
| Counting range                          | -2147483648~2147483647  |
| Pulse mode                              | ABZ-phase quadrature pulse/Pulse + direction                          |
| Pulse frequency                         | 100Hz~2MHz  |
| Frequency multiplication mode           | X1/X2/X4  |
| Resolution                              | 1-65535ppr  |
| Counter preset                          | Software preset   |
| Z-pulse calibration                     | Supported by default for Z signa                                      |
| Counter filter                          | (0~65535)*10ns  |
| Number of DIs                           | 3   |
| DI voltage                              | 24VDC±10%   |
| DI edge selection                       | Rising edge/Falling edge/Rising or falling edge                       |
| DI type                                 | Source or sink  |
| DI filter time                          | 0~65535*10ns per channel  |
| DI function                             | 2XLatch, 1XReset  |
| Latched value                           | Latched value 0, latched value 1, and latch completion flags          |
| Hardware reset                          | Rising edge reset   |
| Number of DOs                           | 2   |
| DO voltage                              | 24VDC   |
| DO type                                 | Source type, rated output current 0.16A                               |
| DO function                             | High-speed comparison output  |
| Measurement variable                    | Frequency/Speed   |
| Update time of the measurement function | 20/100/500/1000ms   |
| Gating function                         | Software gate   |
| Weight                                  | Net: 0.15(Kg) Gross: 0.18(Kg)   |
| Dimensions (W×H×D)                      | Product dimension: 12.5×105×96mm<br>Package dimension: 17.5×109×100mm |

● Counting and position measurement

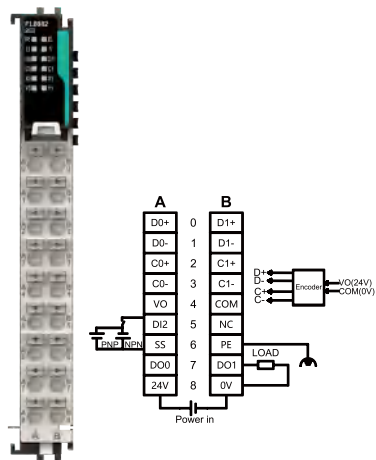

| Model                                   | FL6002  |
|---|---|
| Ordering code                           | 11016-00022   |
| Product category                        | SSI absolute encoder module   |
| Power consumption                       | 0.69W   |
| Number of channels                      | 2   |
| Encoder voltage                         | 24VDC   |
| Encoder signal type                     | RS422 electrical level standards, differential input                          |
| SSI frame length                        | 10~40 (Default: 13)   |
| SSI clock frequency                     | 125K/250K/500K/1M/1.5M/2MHz   |
| Signal type                             | Gray code (default) / Binary  |
| SSI interval time                       | (1~65536)*100us   |
| Number of DIs                           | 1 per channel   |
| DI voltage                              | 24VDC   |
| DI edge selection                       | Rising edge/Falling edge/Rising or falling edge                               |
| DI type                                 | Source or sink  |
| DI filter time                          | (1~65536) *0.1us  |
| DI function                             | Latch   |
| Latched value                           | Latched values and latch completion flags                                     |
| Number of DOs                           | 1 per channel   |
| DO voltage                              | 24V   |
| DO type                                 | Source type, rated output current 0.16A                                       |
| DO function                             | High-speed comparison output  |
| Measurement variable                    | Frequency/Speed   |
| Update time of the measurement function | 20/100/500/1000ms   |
| Gating function                         | Software gate   |
| Weight                                  | Net: 0.15(Kg) Gross: 0.18(Kg)   |
| Dimensions (W × H × D)                  | Product dimension: 12.5 × 105 × 96mm<br>Package dimension: 17.5 × 109 × 100mm |

● Resistance bridge measurement

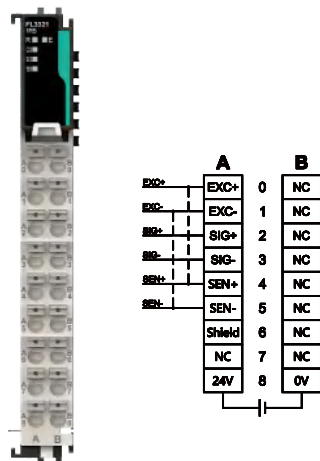

| Model                                 | FL3321   |
|---------------------------------------|--|
| Ordering code                         | 11016-00030  |
| Product type                          | Resistance bridge measurement  |
| Power consumption                     | 0.5W   |
| Number of channels                    | 1  |
| Input sensor type                     | 4-wire or 6-wire bridge sensor   |
| Input mode                            | Differential   |
| Input signal range                    | ±30mVDC  |
| Load cell characteristics             | (1/2/4/6)mV/V  |
| Sampling time                         | 2, 5, 10, 20, 40, 80 (default), 200, 400 ms × channel number (fine-tuning according to the ADC device) |
| Load range                            | 40~4010Ω   |
| Max. exciting current                 | 5V@250mA   |
| ±0.01%FS (25°C, sampling rate < 80ms) | ±0.01%FS (25°C, sampling rate < 80ms)  |
| Accuracy in working temperature       | ±0.05%FS (-25°C~+55°C)   |
| Disconnection detection               | Supported  |
| Short circuit detection               | Exciting power short circuit detection supported   |
| Over range detection                  | Supported  |
| Isolation method                      | Not isolated between channels  |
| Resolution                            | 16 bits  |
| Weight                                | Net: 0.15(Kg) Gross: 0.18(Kg)  |
| Dimensions (W × H × D)                | Product dimension: 12.5 × 105 × 96mm<br>Package dimension: 17.5 × 109 × 100mm                          |

Small PLC

Medium PLC

X86 Controller

I/O System

HMI

Industrial Internet

## ● Resistance bridge measurement

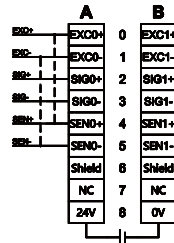

| Model                                  | FL3322   |
|--|--|
| Ordering code                          | 11016-00031  |
| Product type                           | Resistance bridge measurement  |
| Power consumption                      | 0.55W  |
| Number of channels                     | 2  |
| Input sensor type                      | 4-wire or 6-wire bridge sensor   |
| Input mode                             | Differential   |
| Input signal range                     | ±30mVDC  |
| Load cell characteristics              | (1/2/4/6)mV/V  |
| Sampling time                          | 2, 5, 10, 20, 40, 80 (default), 200, 400 ms × channel number (fine-tuning according to the ADC device) |
| Load range                             | 40~4010Ω   |
| Max. exciting current                  | 5V@250mA   |
| Accuracy in room temperature (of 25°C) | ±0.01%FS (25°C, sampling rate < 80ms)  |
| Accuracy in working temperature        | ±0.05%FS (-25°C~+55°C)   |
| Disconnection detection                | Supported  |
| Short circuit detection                | Exciting power short circuit detection supported   |
| Over range detection                   | Supported  |
| Isolation method                       | Not isolated between channels  |
| Resolution                             | 16 bits  |
| Weight                                 | Net: 0.15(Kg) Gross: 0.18(Kg)  |
| Dimensions (W×H×D)                     | Product dimensions: 12.5×105×96mm<br>Package dimensions: 17.5×109×100mm                                |

## ● Pulse module

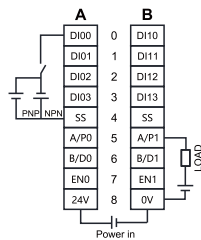

| Model                    | FL7102  |
|--------------------------|---|
| Ordering code            | 11016-00025   |
| Product type             | Pulse output module   |
| Power consumption        | 0.75W   |
| Number of pulse channels | 2   |
| Output mode              | Single-ended NPN output   |
| Output voltage range     | (12~24VDC) ± 15%  |
| Output frequency         | Up to 200kHz  |
| Pulse mode               | Pulse + direction, CW/CCW   |
| Input channel            | 8 channels (4 × 2CH)  |
| Input channel function   | Positive limit, negative limit, origin switch, and emergency stop   |
| Input type               | PNP/NPN   |
| Input voltage range      | 24VDC ± 15%   |
| Input signal logic       | Limit, origin, and emergency stop are individually configured as normally open/normally closed, defaulting to normally open |
| Motion mode              | Absolute position mode, relative position mode, and speed mode  |
| Trapezoidal ACC/DEC      | Supported   |
| Motion merging           | Supported   |
| Homing mode              | 4 modes (19, 21, 24, 28) supported  |
| Forced emergency stop    | Supported   |
| Refresh rate             | ≥ 1ms   |
| Weight                   | Net: 0.15(Kg) Gross: 0.18(Kg)   |
| Dimensions (W×H×D)       | Product dimensions: 12.5×105×96mm<br>Package dimensions: 17.5×109×100mm   |

### ● Power feed module

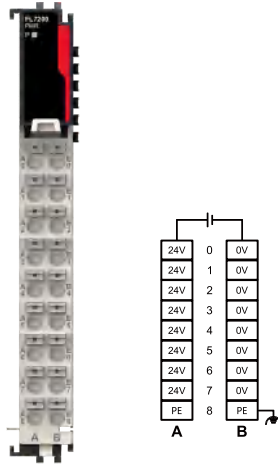

| Model  | FL7200  |
|--|---|
| Ordering code                                      | 11016-00025   |
| Product type                                       | Power feed module   |
| Power consumption                                  | 1.4W  |
| Terminal input power rated voltage                 | 24VDC±15%   |
| Terminal input power rated current                 | 0.7A (typical value at 24V)   |
| Terminal current capacity                          | <4A   |
| Terminal input power reverse connection protection | Supported   |
| Fieldbus output power rated voltage                | 5VDC(4.5VDC ~ 5.5VDC)   |
| Fieldbus output power rated current                | 2.5A (typical value at 25°C ambient temperature)                        |
| Fieldbus output power short circuit protection     | Supported, hiccup-mode protection                                       |
| Isolation method                                   | No isolation  |
| Module addressing                                  | No addressing, no slot occupying  |
| Module status reading                              | Not supported   |
| Weight   | Net: 0.15(Kg) Gross: 0.18(Kg)   |
| Dimensions (W×H×D)                                 | Product dimensions: 12.5×105×96mm<br>Package dimensions: 17.5×109×100mm |

### ● Network components

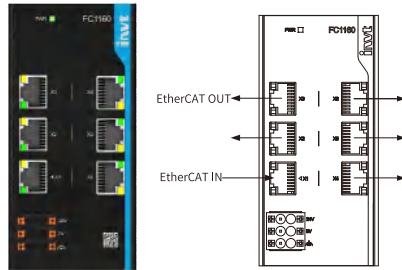

| Model                    | FC1160   |
|--------------------------|--|
| Ordering code            | 11016-00020  |
| Product type             | EtherCAT branch device   |
| Power consumption        | 3.6W   |
| Rated voltage            | 24VDC (-15%~+20%)  |
| Number of EtherCAT ports | 6 (1 input, 5 outputs)   |
| Communication protocol   | EtherCAT   |
| Synchronization method   | Distributed clocks (DCs)   |
| Topology structure       | Star (supporting splitter based cascade)                               |
| Physical layer           | 100BASE-TX   |
| Data transmission rate   | 100MBit/s  |
| Transmission mode        | Full duplex  |
| Output distance          | Less than 100m between the two nodes                                   |
| Weight                   | Net: 0.38(Kg) Gross: 0.41(Kg)  |
| Dimensions (W×H×D)       | Product dimensions: 50×105×112.8mm<br>Package dimensions: 51×112×120mm |

### ● Relay module

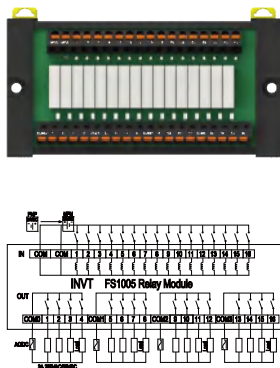

| Model                         | FS1005   |
|-------------------------------|--|
| Ordering code                 | 11016-00024  |
| Product type                  | Digital input and relay output module                                    |
| Power consumption             | 0.23W  |
| Number of input channels      | 16   |
| Input type                    | Source/sink  |
| Input voltage                 | DC24V±10%  |
| Input current (typical value) | 7mA  |
| Max. input frequency          | 500Hz (duty cycle: 40%~60%)  |
| Port filter time              | 10ms   |
| Logic 1 signal                | ≥15V DC  |
| Logic 0 signal                | ≤5V DC   |
| Isolation method              | Relay isolation  |
| Number of output channels     | 16   |
| Output type                   | Relay  |
| Touch point type              | N.O. contact   |
| Contact load (resistive)      | 3A 250VAC/30VDC  |
| Max. switching voltage        | 250VAC/125VDC@0.3A   |
| Max. switching current        | 5A   |
| Relay lifespan                | Electrical: 100,000 times<br>Mechanical: 20 million times                |
| Response time of OFF-ON       | ≤15ms  |
| Response time of ON-OFF       | ≤10ms  |
| Weight                        | Net: 0.157(Kg) Gross: 0.186(Kg)  |
| Dimensions (W×H×D)            | Product dimensions: 129.2×70.9×29.9mm<br>Package dimensions: 142×90×37mm |

## I/O system product list

| Ordering code | Model  | Product type                               | Specifications  |
|---------------|--------|--|---|
| 11016-00005   | FK1100 | Communication coupler (EtherCAT)           | Coupler, EtherCAT, 24VDC; RoHS  |
| 11016-00012   | FK1200 | Communication coupler (Profinet)           | Coupler, Profinet, 24VDC; RoHS  |
| 11016-00018   | FK1300 | Communication Coupler (EtherNet/IP)        | Coupler, EtherNet/IP, 24VDC; RoHS   |
| 11016-00029   | FK1400 | Communication coupler (Modbus TCP)         | Coupler, Modbus TCP, 24VDC; RoHS  |
| 11016-00004   | FL1001 | Digital input                              | Digital input module, 16 channels, supporting the source and sink types, 500mA@ 24 VDC inputs; RoHS                     |
| 11016-00016   | FL1002 | Digital input                              | Digital input module, 32 channels, supporting the source and sink types, 500mA@ 24 VDC inputs; RoHS                     |
| 11016-00006   | FL2002 | Digital output (source type)               | Digital output module, with 16 channels of PNP transistor output, 500mA @ 24 VDC; RoHS                                  |
| 11016-00013   | FL2003 | Digital output (source type)               | Digital output module, with 32 channels of PNP transistor output, 500mA @ 24 VDC; RoHS                                  |
| 11016-00003   | FL2102 | Digital output (sink type)                 | Digital output module, with 16 channels of NPN transistor output, 500mA @ 24 VDC; RoHS                                  |
| 11016-00017   | FL2103 | Digital output (sink type)                 | Digital output module, with 32 channels of NPN transistor output, 500mA @ 24 VDC; RoHS                                  |
| 11016-00045   | FL5004 | Digital input/output (source type)         | Digital input/output, 8 channels of PNP input, 8 channels of PNP transistor output; RoHS                                |
| 11016-00044   | FL5104 | Digital input/output (sink type)           | Digital input/output, 8 channels of NPN input, 8 channels of NPN transistor output; RoHS                                |
| 11016-00015   | FL5005 | Digital input/output (source type)         | Digital input/output, 16 channels of input, 16 channels of PNP transistor output; RoHS                                  |
| 11016-00014   | FL5105 | Digital input/output (sink type)           | Digital input/output, 16 channels of input, 16 channels of NPN transistor output; RoHS                                  |
| 11016-00009   | FL2201 | Digital output (relay)                     | Digital output, 8 relay outputs, dry contacts, 3A@30VDC/250VAC; RoHS  |
| 11016-00011   | FL3003 | Analog input                               | Analog input, 4 channels, 16-bit resolution, room-temperature accuracy of $\pm 0.1\%$ FS; RoHS                          |
| 11016-00026   | FL3404 | Analog input                               | Analog input; 8 channels; voltage signals; 16-bit resolution; accuracy $\pm 0.15\%$ FS at room temperature              |
| 11016-00027   | FL3504 | Analog input                               | Analog input; 8 channels; current signal; 16-bit resolution; accuracy $\pm 0.15\%$ FS at room temperature               |
| 11016-00008   | FL4003 | Analog output                              | Analog output module, 4 channels, 16-bit resolution, room-temperature accuracy of $\pm 0.1\%$ FS; RoHS                  |
| 11016-00007   | FL3103 | Temperature measurement (thermal resistor) | Thermal resistor detection, 4 channels, 24-bit resolution, sensitivity of $0.1^{\circ}\text{C}/^{\circ}\text{F}$ ; RoHS |
| 11016-00010   | FL3203 | Temperature measurement (thermocouple)     | Thermocouple detection, 4 channels, 24-bit resolution, sensitivity of $0.1^{\circ}\text{C}/^{\circ}\text{F}$ ; RoHS     |
| 11016-00019   | FL6112 | Counting module                            | Incremental encoder input, 2 channels, 24V single-ended, 200kHz; RoHS   |
| 11016-00021   | FL6121 | Counting module                            | Incremental encoder input, 1 channel, 5VDC differential, 2MHz; RoHS   |
| 11016-00022   | FL6002 | Counting module                            | SSI absolute input encoder module, 2 channels, 24VDC, 2MHz; RoHS  |
| 11016-00030   | FL3321 | Resistance bridge measurement              | 4-wire/6-wire resistor bridge sensor input, 1 channel, 24-bit, 5VDC, RoHS   |
| 11016-00031   | FL3322 | Resistance bridge measurement              | 4-wire/6-wire resistor bridge sensor input, 2 channel, 24-bit, 5VDC, RoHS   |
| 11016-00025   | FL7102 | Pulse module                               | Pulse output, 2 channels, 200kHz; RoHS  |
| 11016-00028   | FL7200 | Power feed module                          | Power feed; input: 24VDC, output: 5VDC 2.5A; RoHS   |
| 11016-00020   | FC1160 | EtherCAT branch device                     | Network component, EtherCAT, 6 ports, 100Mbit/s, 24VDC; RoHS  |
| 11016-00024   | FS1005 | Relay module                               | 16 channels of input, supporting source/sink type, 16 channels of relay output, 5A@250VAC/30VDC                         |



# HMI

Friendly human-machine interaction experience



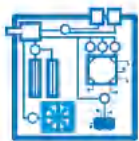

### Powerful CPU

- Stable, efficient, safe, and reliable run in Linux.
- Industrial-grade high-performance processor.
- Cortex A7 CPU, with the main frequency up to 1.2GHz.



### Diversified communication

- Multi-serial communication (RS232/422/485).
- Ethernet communication.
- Allowing one screen or multi-screen for one machine, or multi-screen for multi-machine.
- Optional IoT module, supporting remote monitoring, and remote program uploading and downloading.



### Convenient configuration

- Multi-set recipes, multi-window function.
- Data acquisition, data alarm function.
- Macros are supported.
- Support for custom vector graphics.

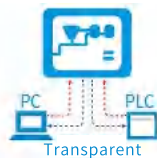

### Featured function

- PC can communicate directly with the PLC via the HMI.
- Online simulation function, PC can be directly connected to the PLC simulation configuration project.
- USB, Ethernet, U disk three ways to update the configuration of the project.



### IoT operation and maintenance

- Supporting WiFi networking method.
- Supporting remote upload and download, firmware update HMI/PLC.
- Supporting cloud platform data monitoring, historical data storage, and alarm push.
- Supporting cloud configuration, GIS mapping, and monitoring via the mobile app.



### Safe and reliable

- Industrial-grade design, stable operation.
- High-capacity FLASH supports permanent storage of large capacity data without loss of power.
- Support USB flash drive data storage.
- New password mechanism, more secure and reliable to use.

## VS-Q series

- 4.3/7.0/10.2/15.6"
- 16.77 million colors of true color display
- C language macros



### Technical specification

| Model                           | VS-043QE                         | VS-043QS  | VS-070QE   | VS-070QS   | VS-070QS-G | VS-102QS-G | VS-102QS   | VS-156QS   |                  |  |
|---------------------------------|----------------------------------|-----------|------------|------------|------------|------------|------------|------------|------------------|--|
| <b>Display</b>                  |                                  |           |            |            |            |            |            |            |                  |  |
| Display size                    | 4.3"                             | 4.3"      | 7"         | 7"         | 7"         | 10.2"      | 10.2"      | 15.6"      |                  |  |
| Resolution                      | 480×272                          | 480×272   | 800×480    | 800×480    | 1024×600   | 1024×600   | 1024×600   | 1920×1080  |                  |  |
| Screen material                 | ITO                              |           |            |            |            |            |            |            |                  |  |
| Color depth                     | 24 bits                          |           |            |            |            |            |            |            |                  |  |
| Brightness (cd/m <sup>2</sup> ) | 400                              |           |            | 450        |            |            | 300        |            |                  |  |
| Backlight type                  | LED                              |           |            |            |            |            |            |            |                  |  |
| Backlight life (hr)             | 20000                            |           |            |            |            |            |            |            | 15000            |  |
| Touch panel type                | 4-wire high accuracy touch panel |           |            |            |            |            |            |            |                  |  |
| <b>CPU and memory</b>           |                                  |           |            |            |            |            |            |            |                  |  |
| CPU                             | Cortex-A7 1GHz (dual core)       |           |            |            |            |            |            |            | Cortex-A7 1.2GHz |  |
| Memory                          | 128M DDR3                        |           |            |            |            |            |            |            | 256M DDR3        |  |
| Flash                           | 128M Flash                       |           |            |            |            |            |            |            | 4G (EMMC)        |  |
| <b>Communication interface</b>  |                                  |           |            |            |            |            |            |            |                  |  |
| USB                             | USB Client ×1, USB Host ×1       |           |            |            |            |            |            |            |                  |  |
| Serial * interface              | COM1                             | RS232     | RS485      | RS232      | RS232      | RS232      | RS232      | RS232      | RS232            |  |
|                                 | COM2                             | RS485/422 | -          | RS485/422  | RS485/422  | RS485/422  | RS485/422  | RS485/422  | RS485/422        |  |
|                                 | COM3                             | -         | -          | RS485      | RS485      | RS485      | RS485      | RS485      | RS485            |  |
| Ethernet                        | -                                | Support   | -          | Support    | Support    | Support    | Support    | Support    |                  |  |
| SD card slot                    | -                                |           |            |            |            |            |            |            |                  |  |
| WIFI                            | -                                |           |            | Support    |            |            |            | -          |                  |  |
| <b>Power supply</b>             |                                  |           |            |            |            |            |            |            |                  |  |
| Rated voltage                   | 12-24VDC (±15%)                  |           |            |            |            |            |            |            |                  |  |
| Rated power                     | 3W                               |           |            | 4W         |            |            | 7W         |            | 10W              |  |
| <b>Environment</b>              |                                  |           |            |            |            |            |            |            |                  |  |
| Work temperature                | -20~55 °C                        |           |            |            |            |            |            |            |                  |  |
| Work humidity                   | 5~95%RH (No condensation)        |           |            |            |            |            |            |            |                  |  |
| Protection level                | IP65 (front panel)               |           |            |            |            |            |            |            |                  |  |
| <b>Certification</b>            |                                  |           |            |            |            |            |            |            |                  |  |
| CE                              | En55032, EN55035                 |           |            |            |            |            |            |            |                  |  |
| FCC compatibility               | FCC, Class A                     |           |            |            |            |            |            |            |                  |  |
| <b>Dimensions and weight</b>    |                                  |           |            |            |            |            |            |            |                  |  |
| Physical dimension W*H*D (mm)   | 139×86×31                        | 139×86×31 | 203×145×35 | 203×145×35 | 203×145×35 | 273×211×40 | 273×211×40 | 395×257×31 |                  |  |
| Hole dimension A*B (mm)         | 132×80                           | 132×80    | 192×138    | 192×138    | 192×138    | 259×201    | 259×201    | 383×246    |                  |  |
| Weight (Kg)                     | 0.2                              | 0.2       | 0.7        | 0.7        | 0.7        | 1.05       | 1.05       | 2.45       |                  |  |
| <b>Configuration</b>            |                                  |           |            |            |            |            |            |            |                  |  |
| Configuration software          | HMITOOL                          |           |            |            |            |            |            |            |                  |  |

Note: ● Indicates Support - Indicates not supported \* In the serial interface, DB9 is a male socket

### Dimension

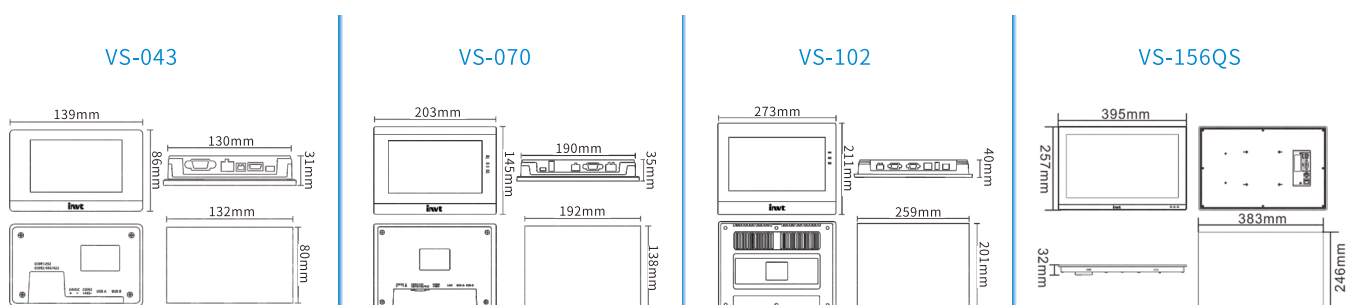

## VA series

- 7.0/10.1"
- 3 serial ports
- Backlight life 20,000hrs
- Up to 30 screens, 100 macros



## Technical specification

| Model                           |      | VA2070-N0CXR                      | VA2100-N0CXR     |
|---------------------------------|------|-----------------------------------|------------------|
| <b>Display</b>                  |      |                                   |                  |
| Display size                    |      | 7"                                | 10.1"            |
| Resolution                      |      | 800×480                           | 1024×600         |
| Screen material                 |      | TFT                               |                  |
| Color depth                     |      | 16 bits                           |                  |
| Brightness (cd/m <sup>2</sup> ) |      | 350                               | 250              |
| Backlight type                  |      | LED                               |                  |
| Backlight life (hr)             |      | 20000                             |                  |
| Touch panel type                |      | 4-wire resistive screen           |                  |
| <b>CPU and memory</b>           |      |                                   |                  |
| CPU                             |      | RISC ARM9 32Bit 300MHz            |                  |
| Memory                          |      | 64MB DDR3                         |                  |
| Flash                           |      | 128MB Flash                       |                  |
| Number of screens               |      | 30 pages                          |                  |
| <b>Interface</b>                |      |                                   |                  |
| USB                             |      | Host: USB2.0×1 / Client: USB2.0×1 |                  |
| Serial *<br>interface           | COM1 | RS232 (DB9)                       | RS232 (DB9)      |
|                                 | COM2 | RS485/422 (DB9)                   | RS485/422 (DB9)  |
|                                 | COM3 | RS485 (DB9)                       | RS485 (DB9)      |
| Ethernet interface              |      | -                                 | -                |
| Micro SD card slot              |      | -                                 | -                |
| <b>Power supply</b>             |      |                                   |                  |
| Rated voltage                   |      | 24VDC (±10%)(Isolation)           |                  |
| Rated power                     |      | 10W                               | 20W              |
| <b>Environment</b>              |      |                                   |                  |
| Work temperature                |      | -10~50°C                          |                  |
| Work humidity                   |      | 10~90%RH (No condensation)        |                  |
| Protection level                |      | IP54 (Front board)                |                  |
| <b>Certification</b>            |      |                                   |                  |
| CE                              |      | EN61000-6-2, EN61000-6-4          |                  |
| FCC compatibility               |      | FCC, Class A                      |                  |
| RoHS                            |      | ●                                 | ●                |
| <b>Dimensions and wight</b>     |      |                                   |                  |
| Physical dimension W*H*D (mm)   |      | 203.5×148.5×31.5                  | 270.8×212.8×42.5 |
| Hole dimension A*B (mm)         |      | 191.5×138                         | 259×201          |
| Weight (Kg)                     |      | 0.55                              | 1.1              |
| <b>Configuration</b>            |      |                                   |                  |
| Configuration software          |      | VT Designer                       |                  |

Note: ● Indicates Support - Indicates not supported \* In the serial interface, DB9 is a female socket

## Dimension

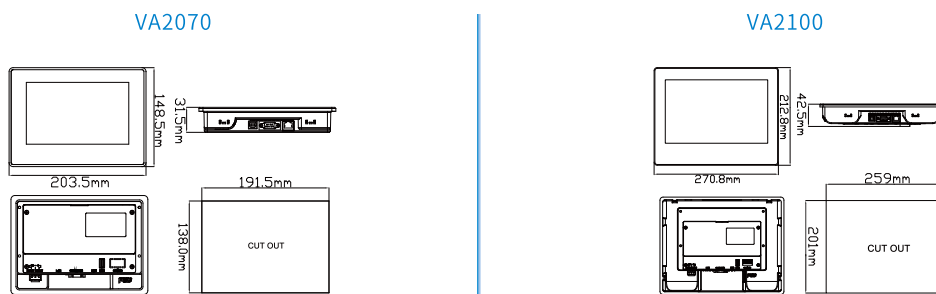

## VK series

- 4.3/7.0/10.1"
- 3 serial ports
- Backlight life 20,000hrs
- Support macros



## Technical specification

| Model                           | VK2043-N0CXN                              | VK2043-N0CXR                     | VK2043-N0EXR                         | VK2070-N0EXR      | VK2070-N0CXR    | VK2100-N0CXR     | VK2100-N0EXR      |
|---------------------------------|---|----------------------------------|--------------------------------------|-------------------|-----------------|------------------|-------------------|
| <b>Display</b>                  |   |                                  |                                      |                   |                 |                  |                   |
| Display size                    | 4.3"                                      | 4.3"                             | 4.3"                                 | 7"                | 7"              | 10.1"            | 10.1"             |
| Resolution                      | 480×272                                   | 480×272                          | 480×272                              | 800×480           | 800×480         | 1024×600         | 1024×600          |
| Screen material                 | TFT                                       |                                  |                                      |                   |                 |                  |                   |
| Color depth                     | 16 bits                                   |                                  |                                      |                   |                 |                  |                   |
| Brightness (cd/m <sup>2</sup> ) | 400                                       | 400                              | 400                                  | 400               | 400             | 350              | 350               |
| Backlight type                  | LED                                       |                                  |                                      |                   |                 |                  |                   |
| Backlight life (hr)             | 20000                                     |                                  |                                      |                   |                 |                  |                   |
| Touch panel type                | 4-wire resistive screen                   |                                  |                                      |                   |                 |                  |                   |
| <b>CPU and memory</b>           |   |                                  |                                      |                   |                 |                  |                   |
| CPU                             | RISC ARM9 32Bit 300MHz                    |                                  |                                      |                   |                 |                  |                   |
| Memory                          | 64MB DDR3                                 |                                  |                                      |                   |                 |                  |                   |
| Flash                           | 128MB Flash                               |                                  |                                      |                   |                 |                  |                   |
| Number of screens               | 7999 pages                                |                                  |                                      |                   |                 |                  |                   |
| <b>Interface</b>                |   |                                  |                                      |                   |                 |                  |                   |
| USB                             | USB Host: USB2.0×1 / USB Client: USB2.0×1 |                                  |                                      |                   |                 |                  |                   |
| Serial interface *              | COM1                                      | -                                | RS232 (5-PIN terminal connector)     |                   | RS232 (DB9)     |                  |                   |
|                                 | COM2                                      | -                                | RS422/485 (5-pin terminal connector) |                   | RS422/485 (DB9) |                  |                   |
|                                 | COM3                                      | RS485 (5-pin terminal connector) |                                      |                   | RS485 (DB9)     |                  |                   |
| Ethernet interface              | -   | -                                | 10M/100M BASE-T×1                    | 10M/100M BASE-T×1 | -               | -                | 10M/100M BASE-T×1 |
| Micro SD card slot              | -   |                                  |                                      |                   |                 |                  |                   |
| <b>Power supply</b>             |   |                                  |                                      |                   |                 |                  |                   |
| Rated voltage                   | 24VDC (±10%)(Isolation)                   |                                  |                                      |                   |                 |                  |                   |
| Rated power                     | 10W                                       | 10W                              | 10W                                  | 20W               | 20W             | 20W              | 20W               |
| <b>Environment</b>              |   |                                  |                                      |                   |                 |                  |                   |
| Work temperature                | -10~60° C                                 |                                  |                                      |                   |                 |                  |                   |
| Work humidity                   | 10~90%RH (No condensation)                |                                  |                                      |                   |                 |                  |                   |
| Protection level                | IP65 (Front board)                        |                                  |                                      |                   |                 |                  |                   |
| <b>Certification</b>            |   |                                  |                                      |                   |                 |                  |                   |
| CE                              | EN61000-6-2, EN61000-6-4                  |                                  |                                      |                   |                 |                  |                   |
| FCC compatibility               | FCC, Class A                              |                                  |                                      |                   |                 |                  |                   |
| RoHS                            | ●   | ●                                | ●                                    | ●                 | ●               | ●                | ●                 |
| <b>Dimensions and weight</b>    |   |                                  |                                      |                   |                 |                  |                   |
| Physical dimension W*H*D (mm)   | 129×103×33                                | 129×103×33                       | 129×103×33                           | 203.5×148.5×37    | 203.5×148.5×37  | 270.8×212.8×42.5 | 270.8×212.8×42.5  |
| Hole dimension A*B (mm)         | 118.5×92.5                                | 118.5×92.5                       | 118.5×92.5                           | 191.5×138         | 191.5×138       | 259×201          | 259×201           |
| Weight (Kg)                     | 0.23                                      | 0.23                             | 0.23                                 | 0.55              | 0.55            | 1.1              | 1.1               |
| <b>Configuration</b>            |   |                                  |                                      |                   |                 |                  |                   |
| Configuration software          | VT Designer                               |                                  |                                      |                   |                 |                  |                   |

Note: ● Indicates Support - Indicates not supported \* In the serial interface, DB9 is a female socket

## Dimension

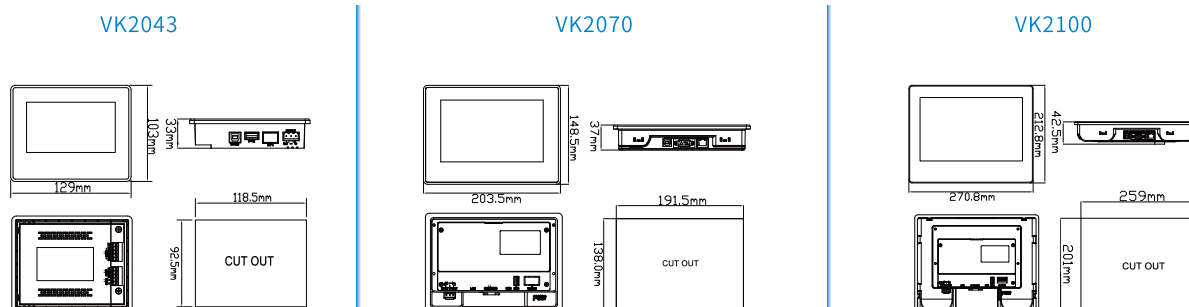

## VT series

- 7.0/10.4"
- Up to 5 serial ports
- Isolation design
- Backlight life 20,000hrs
- Support macros



## Technical specification

| Model                           |      | VT2070-NOCTR-24 | VT2070-H1ETR-31                           | VT2104-H0ETR-51        |
|---------------------------------|------|-----------------|---|------------------------|
| <b>Display</b>                  |      |                 |   |                        |
| Display size                    |      | 7"              | 7"  | 10.4"                  |
| Resolution                      |      | 800×480         | 800×480                                   | 800×600                |
| Screen material                 |      |                 | TFT                                       |                        |
| Color depth                     |      |                 | 16 bits                                   |                        |
| Brightness (cd/m <sup>2</sup> ) |      |                 | 400                                       |                        |
| Backlight type                  |      |                 | LED                                       |                        |
| Backlight life (hr)             |      |                 | 20000                                     |                        |
| Touch panel type                |      |                 | 4-wire resistive screen                   |                        |
| <b>CPU and memory</b>           |      |                 |   |                        |
| CPU                             |      |                 | RISC ARM9 32Bit 300MHz                    |                        |
| Memory                          |      |                 | 64MB DDR3                                 |                        |
| Flash                           |      |                 | 128MB Flash                               |                        |
| Number of screens               |      |                 | 7999 pages                                |                        |
| <b>Interface</b>                |      |                 |   |                        |
| USB                             |      |                 | USB Host: USB2.0×1 / USB Client: USB2.0×1 |                        |
| Serial *<br>interface           | COM1 | RS232 (DB9)     | RS232/422/485 (DB9)                       | RS232 (DB9)            |
|                                 | COM2 | RS422/485 (DB9) | RS485 (5-PIN terminal)                    | RS422/485 (DB9)        |
|                                 | COM3 | -               | RS485 (DB9)                               | RS485 (DB9)            |
|                                 | COM4 | -               | -   | RS485 (5-pin terminal) |
|                                 | COM5 | -               | -   | RS485 (5-pin terminal) |
| Ethernet interface              |      | -               | 10/100M BASE-T×1                          | 10/100M BASE-T×1       |
| Micro SD card slot              |      | -               | Micro SD                                  | -                      |
| <b>Power supply</b>             |      |                 |   |                        |
| Rated voltage                   |      |                 | 24VDC (±10%)(Isolation)                   |                        |
| Rated power                     |      | 20W             | 20W                                       | 20W                    |
| <b>Environment</b>              |      |                 |   |                        |
| Work temperature                |      |                 | -10~60°C                                  |                        |
| Work humidity                   |      |                 | 10~90%RH (No condensation)                |                        |
| Protection level                |      |                 | IP66 (Front board)                        |                        |
| <b>Certification</b>            |      |                 |   |                        |
| CE                              |      |                 | EN61000-6-2, EN61000-6-4                  |                        |
| FCC compatibility               |      |                 | FCC, Class A                              |                        |
| RoHS                            |      | ●               | ●   | ●                      |
| <b>Dimensions and wight</b>     |      |                 |   |                        |
| Physical dimension W*H*D (mm)   |      | 188×143.3×40    | 188×143.3×40                              | 270.8×212.8×42.5       |
| Hole dimension A*B (mm)         |      | 174.5×132.5     | 174.5×132.5                               | 259×201                |
| Weight (Kg)                     |      | 0.55            | 0.55                                      | 1.1                    |
| <b>Configuration</b>            |      |                 |   |                        |
| Configuration software          |      |                 | VT Designer                               |                        |

Note: ● Indicates Support - Indicates not supported \* In the serial interface, DB9 is a female socket

## Dimension

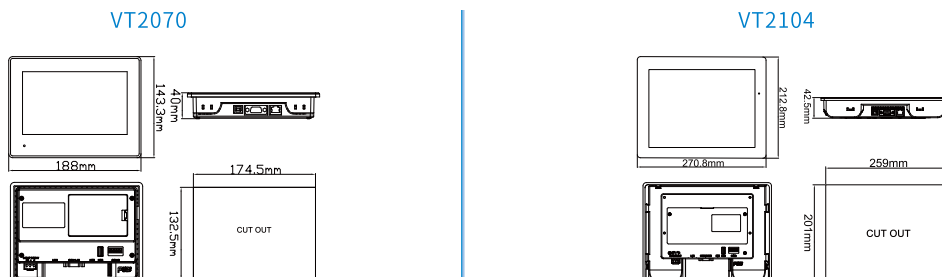

## VS Series Intergrated Machine

- Size of 7.0 inches
- HMI-PLC AIO
- Diverse communication methods
- Easy configuration



### Technical specification

| Model                           |      | VS070QS-1618MDM1          |
|---------------------------------|------|---------------------------|
| <b>Display</b>                  |      |                           |
| Display size                    |      | 7"                        |
| Resolution                      |      | 800×480                   |
| Screen material                 |      | TFT                       |
| Color depth                     |      | 24 bits                   |
| Brightness (cd/m <sup>2</sup> ) |      | 450                       |
| Backlight type                  |      | LED                       |
| Backlight life (hr)             |      | 20000                     |
| Touch panel type                |      | 4-wire resistive          |
| <b>Processor and memory</b>     |      |                           |
| Processor                       |      | Cortex-A7 1GHz            |
| Memory                          |      | 128MB DDR3                |
| Flash memory                    |      | 128MB Flash               |
| <b>Interface</b>                |      |                           |
| USB                             |      | USB Host×1 / USB Client×1 |
| Serial *<br>interface           | COM1 | RS485                     |
|                                 | COM2 | RS232                     |
| Ethernet                        |      | Supported                 |
| SD card socket                  |      | -                         |
| <b>Power supply</b>             |      |                           |
| Rated voltage                   |      | 24VDC (±15%)              |
| Rated power                     |      | 7W                        |
| <b>Input</b>                    |      |                           |
| Digital                         |      | 16                        |
| Analog                          |      | 2 channels                |
| <b>Output</b>                   |      |                           |
| Digital                         |      | 18                        |
| Analog                          |      | 1 channel                 |
| <b>Environment</b>              |      |                           |
| Working temperature             |      | -20~55°C                  |
| Working humidity                |      | 5~95%RH (no condensation) |
| IP rating                       |      | IP65 (front panel)        |
| <b>Certification</b>            |      |                           |
| CE                              |      | En55032, En55035          |
| FCC compatibility               |      | FCC, Class A              |
| RoHS                            |      | ●                         |
| <b>Dimensions and wight</b>     |      |                           |
| Physical dimension W*H*D (mm)   |      | 203×145×56                |
| Hole dimension A*B (mm)         |      | 192×138                   |
| Weight (Kg)                     |      | 0.8                       |
| <b>Configuration</b>            |      |                           |
| Configuration software          |      | HMI TOOL + Auto Station   |

Note: ● Indicates Support - Indicates not supported \* In the serial interface, DB9 is a female socket

### Dimension

VS070QS-1618MDM1

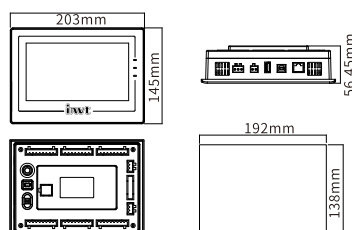

## HMI-VS-Q series wireless module

Modules can be mounted to the HMI interface with fasteners, plug and play



| Product model                 | VS-Q-WIFI  |
|-------------------------------|--|
| Networking method             | WIFI   |
| Network frequency             | IEEE 802.11b                                       |
| frequency band                | IEEE 802.11g                                       |
|                               | IEEE 802.11n                                       |
| Network reconnection          | Supported  |
| Offline transmission resuming | Supported  |
| API interface                 | Supported  |
| VNC function                  | Supported  |
| Data monitoring               | Support up to 280 data points                      |
| Historical data               | Supports up to 20,000 data items                   |
| Alarm push                    | Support client push and WeChat public account push |

IWOcloud IoT cloud platform free application

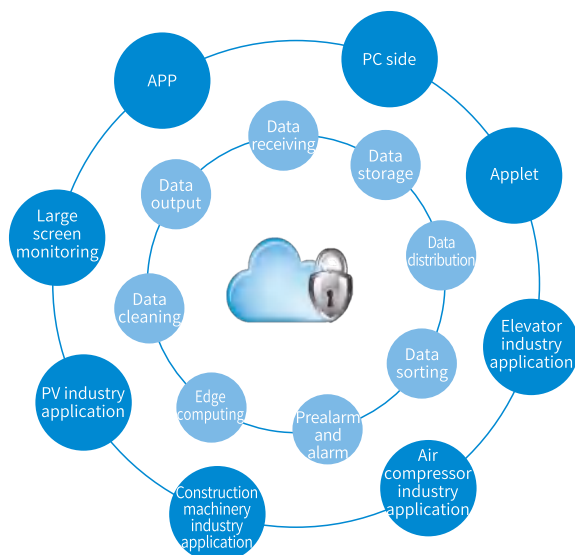

## HMI product list

| Product     | Material code | Model            | Description  | Cut-out size  |
|-------------|---------------|------------------|--|---|
| VS-Q series | 11026-00025   | VS-043QE         | 4.3", 480×272, 24bit color, 2 serial port, RoHS  | 132×84mm  |
|             | 11026-00031   | VS-043QS         | 4.3", 480×272, 24bit color, 2 serial port, 1 Ethernet port, RoHS   | 132×84mm  |
|             | 11026-00022   | VS-070QE         | 7.0", 800×480, 24bit color, 3 serial port, RoHS  | 192×138mm   |
|             | 11026-00023   | VS-070QS         | 7.0", 800×480, 24bit color, 3 serial ports, 1 Ethernet port, RoHS  | 192×138mm   |
|             | 11026-00029   | VS-070QS-G       | 7.0", 800×480, 24bit color, 3 serial ports, 1 Ethernet port, support the expansion of the IoT, RoHS  | 192×138mm   |
|             | 11026-00024   | VS-102QS         | 10.2", 1024×600, 24bit color, 3 serial port, 1 Ethernet port, RoHS   | 259×201mm   |
|             | 11026-00028   | VS-102QS-G       | 10.2", 1024×600, 24bit color, 3 serial port, 1 Ethernet port, support the expansion of the IoT, RoHS   | 259×201mm   |
|             | 11026-00026   | VS-156QS         | 15.6", 1920×1080, 24bit color, 3 serial port, 1 Ethernet port, RoHS  | 383×246mm   |
|             | 11095-00023   | VS-Q-WIFI        | Wi-Fi module, supporting network frequency segments IEEE802.11b, IEEE802.11g, IEEE802.11n, need to be used with the IoT screen                   | -   |
| VA series   | 11060-00320   | VS070QS-1618MDM1 | 7.0" Inch AIO, with built-in 16 channels of digital input, 18 channels of digital output, 2 channels of analog input, 1 channel of analog output | 192×138mm   |
|             | 11060-00156   | VA2070-N0CX      | 7.0", 800×480, 16bit color, 3 serial ports, no Ethernet port   | 191.5×138mm   |
| VK series   | 11060-00157   | VA2100-N0CX      | 10.1", 1024×600, 16bit color, 3 serial ports, no Ethernet port   | 259×201mm   |
|             | 11060-00172   | VK2043-N0CXN     | 4.3", 480×272, 16bit color, 2 serial ports, no Ethernet port   | 118.5×92.5mm  |
|             | 11060-00272   | VK2043-N0CX      | 4.3", 480×272, 16bit color, 3 serial ports, no Ethernet port   | 118.5×92.5mm  |
|             | 11060-00173   | VK2043-N0EXR     | 4.3", 480×272, 16bit color, 3 serial ports, 1 Ethernet port  | 118.5×92.5mm  |
|             | 11060-00169   | VK2070-N0EXR     | 7.0", 800×480, 16bit color, 3 serial ports, 1 Ethernet port  | 191.5×138mm   |
|             | 11060-00171   | VK2070-N0CX      | 7.0", 800×480, 16bit color, 3 serial ports, no Ethernet port   | 191.5×138mm   |
|             | 11060-00168   | VK2100-N0CX      | 10.1", 1024×600, 16bit color, 3 serial ports, no Ethernet port   | 259×201mm   |
|             | 11060-00167   | VK2100-N0EXR     | 10.1", 1024×600, 16bit color, 3 serial ports, 1 Ethernet port  | 259×201mm   |
|             | VT series     | 11026-00017      | VT2070-H1ETR-31  | 7.0", 800×480, 16bit color, 3 serial ports, 1 Ethernet port |
| 11026-00018 |               | VT2070-N0CTR-24  | 7.0", 800×480, 16bit color, 32 serial ports, no Ethernet port, 1MB (backup)  | 174.5×132.5mm   |
| 11026-00016 |               | VT2104-H0ETR-51  | 10.4", 800×600, 16bit color, 5 serial ports, 1 Ethernet port   | 259×201mm   |

# Industrial Internet

Cloud platform | Application system | Cloud platform | Cloud services

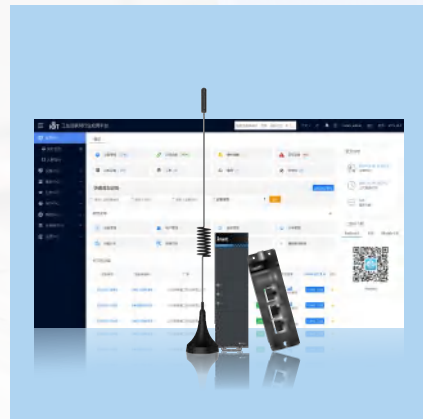

INVT independently develops and owns four industrial Internet products, namely, IWOCLOUD industrial Internet cloud platform, WOScene application system, IWOLink data terminal products, and ICS industrial cloud service. In combination with INVT industrial automation products, we provide end-to-end integrated solutions for industry customers, helping them to move towards a new journey of digital transformation!

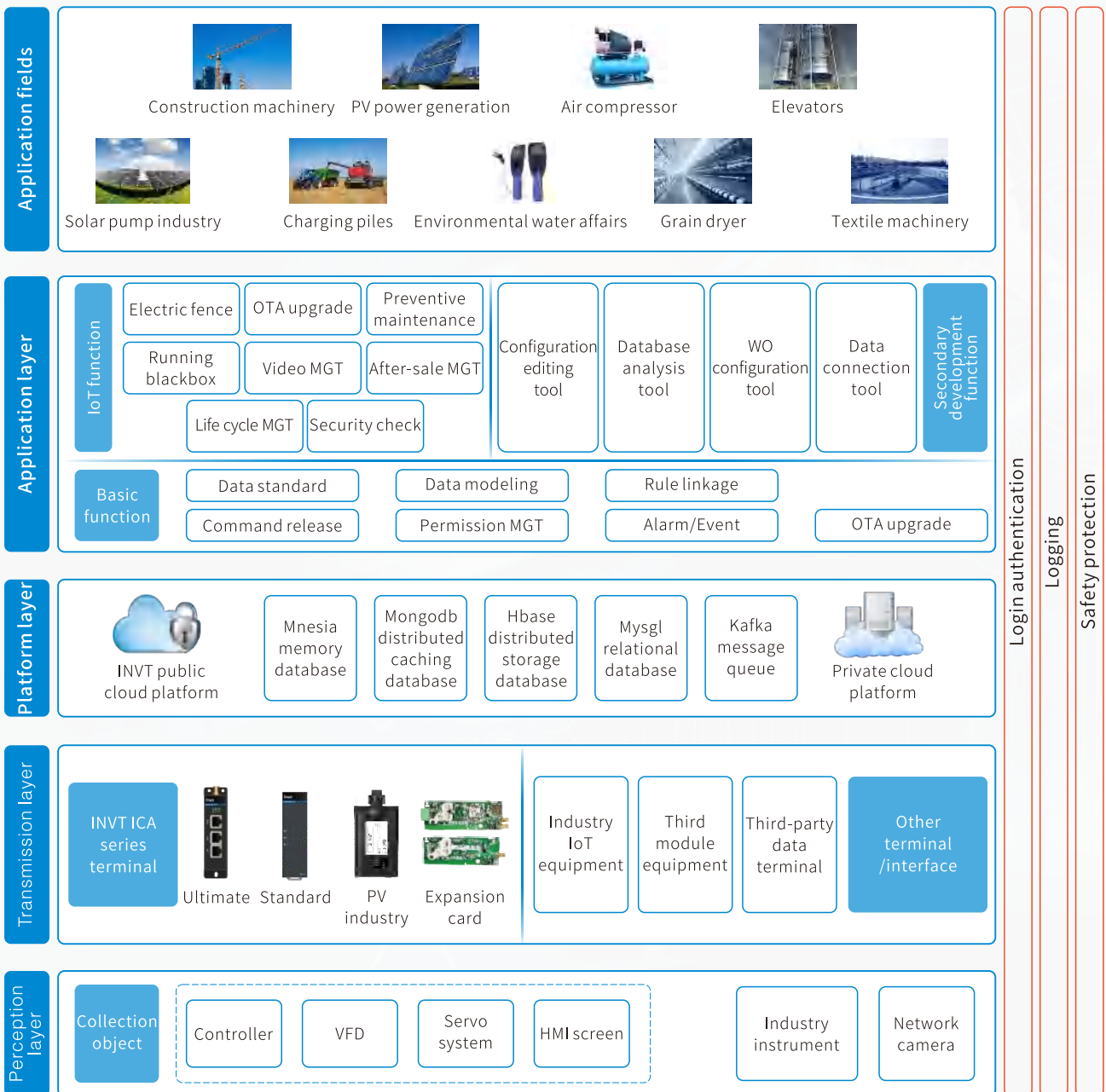

## IWOScene-SCADA: acquisition and monitoring system

Integrate equipment monitoring functions in various dimensions to meet the needs for equipment monitoring, including real-time monitoring of the safe operation, operation efficiency and effectiveness of the equipment in the form of large screens.

### ● Data cockpit

#### Management without leaving home

Through web pages in a mobile or a computer, large screen monitoring and other forms, you can quickly grasp the APP real-time status of the equipment, and carry out video monitoring, remote start/stop, and modification of parameters, and so on.

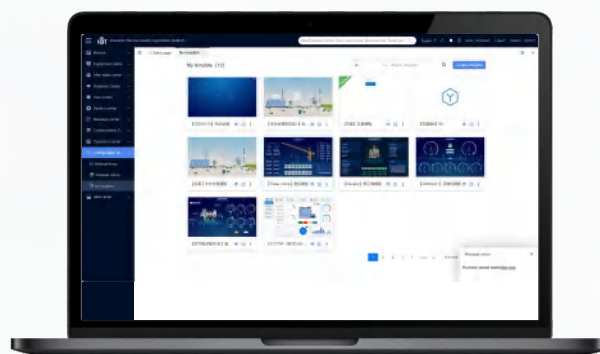

### ● Free configuration monitoring

#### Manage affairs without leaving home

The platform has built-in configuration editing tools, allowing users to configure their own configuration monitoring pages.



### ● Historical data

Integrates the functions for system operation and daily platform management to meet the needs for system management, including system settings, operation records, user data statistics, enterprise dynamic management, etc.

### ● Historical data query

#### Multidimensional application of data

You can customize the type of the focused parameter, address, type, chart, and fault.  
You can also customize data charts for display, and export historical data to the local server in various types of files.

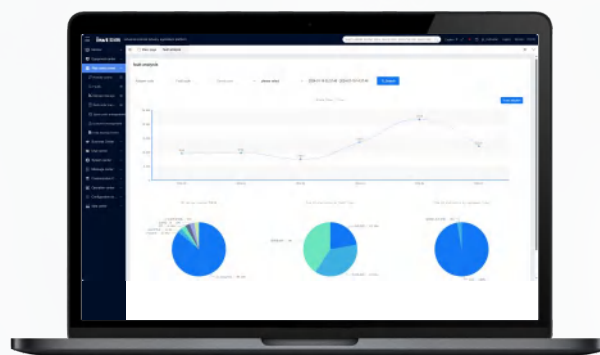

- Data analysis and statistics

### Objective data support for fault analysis

For historical data, various statistical reports can be customized and generated, facilitating multi-dimensional data analysis applications. Based on different user needs, statistical analysis includes the assessment and statistical analysis of various equipment parameters, providing objective data support for decision-making in various departments such as research and development, after-sales, and sales.

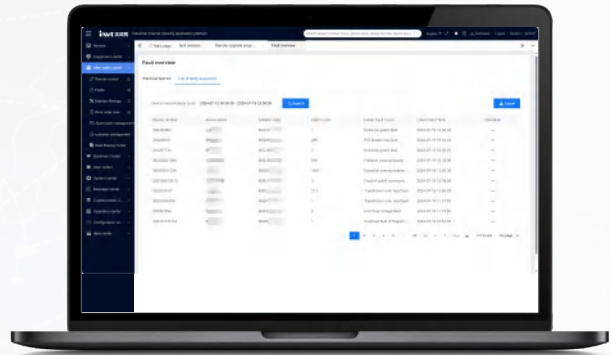

## IWOScene-OMS: Operation and maintenance system

- Remote assistance

- Remote upgrade of equipment

### Remote upgrade without leaving home

You can remotely upload, download, and monitor device equipment programs, including PLC, VFD, data terminal modules, etc.

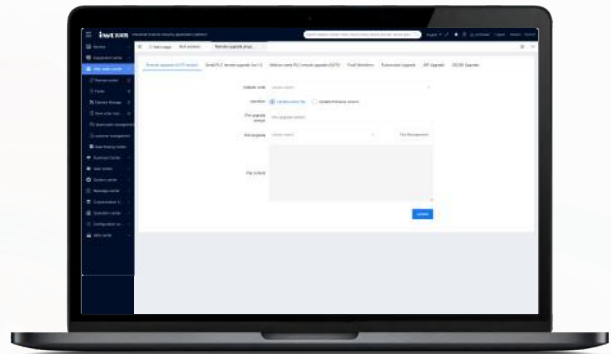

- Fault management

- Fault pre-alarm/alarm

### Electronic sentry, real-time guarding of equipment

The system provides timely feedback on alarm information and push them through APP SMS, e-mail and other forms. For the key parameters of the key equipment, pre-alarm values can be set to detect faults before they occur.

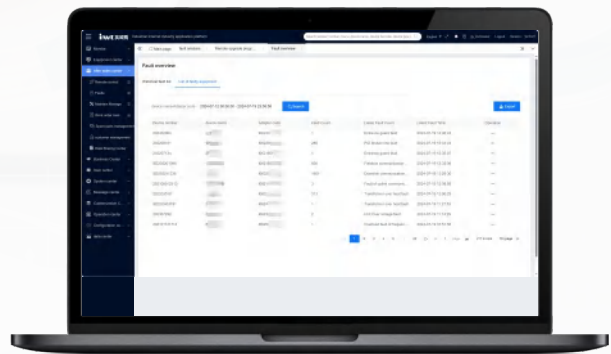

Integrates functions for after-sales maintenance, improving the efficiency of after-sales maintenance of user equipment, including: fault management, maintenance management, work order management, spare parts management, etc.

● Preventive maintenance

**Passive after-sales service becomes proactive service**

This includes prediction of equipment service life, preventive cleaning of key components, life cycle management of maintenance parts, equipment exception pre-alarm, etc.

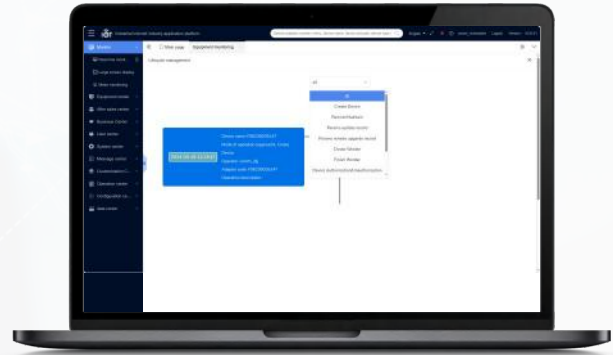

● Maintenance management

**"Digital housekeeper" of equipment**

The system can set the maintenance cycle for the monitoring equipment as a whole or components, and the maintenance logic can be customized, including countdown and event triggering.

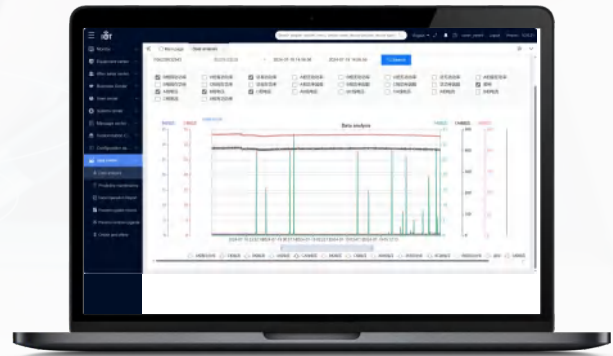

● Work order management

● After-sale WO management

**Online processing of after-sale business**

You can circulate a series of after-sales work orders such as faults, installation, and repair, and monitor the entire process of handling the results, improving the efficiency of after-sales maintenance work, enhancing user experience and corporate image.

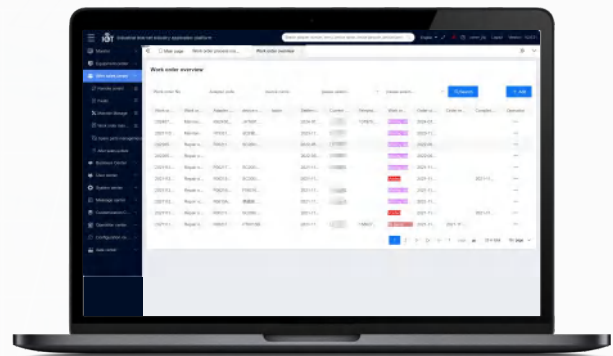

Small PLC  
Medium PLC  
X86 Controller  
I/O System  
HMI  
Industrial Internet

## System features

INVT provides industrial enterprises with complete, reliable, flexible, and quick-deliverable solutions.



### Pan-access

Supporting various VFDs, servo, PLC, and HMI screens.



### Multiple presenting

Supporting PC and mobile app (on Android and iOS)



### Privatization deployment

The system cloud platform supports privatization deployment



### Safe and stable

Supporting the pushing by means of mobile app, email, and SMS message



### Multimedia access

Supporting onsite video, image, and interface access, and AI recognition of face.



### Quick start

Easy to operate and user friendly interface



### Personalized customization

Application system functions can be customized



### Data analysis

Historic data, condition collection, and data reports



### Alarm pushing

Data is encrypted before transmission, and servers are managed in distributed mode



### Data interface

The platform provides the API, eliminating data silos

## Multiple login methods

Go to the login interface through <https://iot.invt.com/> with a PC



Login through the INVT APP with a mobile

Download methods: iOS: App Store > Search "INVTIOT" > Download

Android: App Store > Search "Invt cloud"



## Large-screen application

Customized large-screen display can be applied to system data, which can be planned as follows:

- Macro data: Device distribution map, online/fault/alarm device distribution
- System key statistics: Device status statistics and work order quantity display



## IWOLink data terminal product

To flexibly adapt to the data acquisition needs of various industrial equipment and different network scenarios, INVT has launched a series of data acquisition products to provide fast, easy, and secure IoT data connection solutions.

### ICA417 series

#### Excellent performance

Edge computing, VPN transparent transmission, and remote OTA makes you feel like you are there!



4G Ultimate

### TBox series

#### Super applicability

One device supports multiple scene applications!  
(Serial to 4G, Serial to Network port, Network port to 4G)



4G Standard

### ICA400-06 series

#### With Wi-Fi

Dedicated to the PV industry, worry free network connection!



PV industry

### EC-IC series

#### Perfect match

With a built-in card, traditional devices are perfectly upgraded with IoT functions!



Expansion card

## Technical specifications

| Data Terminal Products                      | TBox  | TBox-EU                   | TBox-LA                         | TBox-4G                              | ICA100-02                 | ICA400-02-CN  | ICA417-02-CN                         |
|---|---|---------------------------|---------------------------------|--------------------------------------|---------------------------|---|--------------------------------------|
| Ordering Code                               | 11095-00035   | 11095-00036               | 11095-00041                     | 11095-00034                          | 11095-00008               | 11095-00004   | 11095-00019                          |
| Product Positioning                         | Standard Version  | Standard European Version | Standard Latin American Version | Youth Version                        | WiFi Version              | 4G-pro Version  | 4G Flagship Version                  |
| SIM Card                                    | Comes with a 1GB/month data SIM card                                  | No SIM card               |                                 | Comes with a 1GB/month data SIM card | No need for a SIM card    | Comes with a 30MB/month data SIM card                             | Comes with a 2GB/month data SIM card |
| <b>Communication Parameters</b>             |   |                           |                                 |                                      |                           |   |                                      |
| Upstream Networking                         | 4G/Ethernet Port/WiFi   |                           |                                 | 4G/Ethernet Port                     | WiFi(2.4GHz)              | 4G  | 4G/Ethernet Port                     |
| Upstream Network Speed                      | 5Mbps   |                           |                                 |                                      | 10Mbps                    | 5Mbps   | 50Mbps                               |
| Downstream Communication                    | RS485/RS232/Ethernet Port   |                           |                                 |                                      | RS485/232                 | RS485/232   | RS485/RS232 /Ethernet Port           |
| Downstream Network Speed                    | 10Mbps  |                           |                                 |                                      | 54Mbps                    | 10Mbps  | 100Mbps                              |
| <b>Hardware Parameters</b>                  |   |                           |                                 |                                      |                           |   |                                      |
| Protection Level                            | IP20  |                           |                                 |                                      |                           |   |                                      |
| Supply Voltage                              | DC 10~24V   |                           |                                 |                                      |                           |   |                                      |
| Overall Power Consumption                   | 3W  |                           |                                 | 2W                                   |                           | 3W  |                                      |
| Indicator Lights                            | Power Indicator, Network Status Indicator, Operation Status Indicator |                           |                                 |                                      |                           |   |                                      |
| Installation Method                         | Standard Rail Mounting  |                           |                                 |                                      |                           |   |                                      |
| Operating Temperature                       | -25°C~65°C  |                           |                                 |                                      |                           |   |                                      |
| International Version                       | CN Version  | EU Version                | LA Version                      | CN Version                           | Internationally Universal | CN Version, This Series Supports EU/LA Versions                   |                                      |
| Antenna                                     | External  |                           |                                 |                                      | WiFi Antenna              | External  |                                      |
| Bluetooth Debugging                         | Supported   |                           |                                 |                                      | Not Supported             |   |                                      |
| Shell Material                              | Engineering Plastic   |                           |                                 |                                      |                           |   | Sheet Metal                          |
| <b>Software Functions</b>                   |   |                           |                                 |                                      |                           |   |                                      |
| Real-time Data Monitoring                   | Supported   |                           |                                 |                                      |                           |   |                                      |
| Edge Computing                              | Supported in Non-standard Cases                                       |                           |                                 |                                      |                           |   |                                      |
| FOTA Remote Upgrade                         | Supports Inverter Upgrade (GD270/350 Platform Dedicated Products)     |                           |                                 |                                      | Not Supported             | Supports Inverter Upgrade (GD270/350 Platform Dedicated Products) |                                      |
| Serial Port Transparency Transmission       | Supported   |                           |                                 |                                      | Not Supported             | Supported   |                                      |
| Ethernet Port VPN Transparency Transmission | Supported   |                           |                                 |                                      | Not Supported             |   | Supported                            |

## Structure size

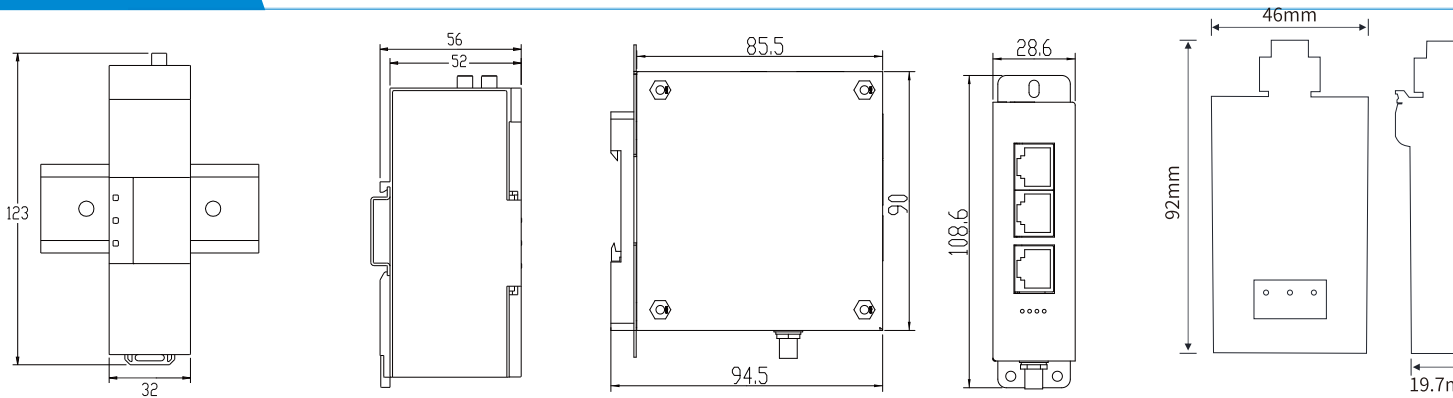

| Model       | Dimensions (W×H×D)<br>(including rail clips) | Weight<br>(excluding antenna) |
|-------------|--|-------------------------------|
| TBox series | 32×123×56mm                                  | 55g                           |

| Model        | Dimensions (W×H×D)<br>(including rail clips) | Weight<br>(excluding antenna) |
|--------------|--|-------------------------------|
| ICA417series | 28.6×108.6×94.5mm                            | 153g                          |

| Model         | Dimensions (W×H×D)<br>(including rail clips) |
|---------------|--|
| ICA-06 series | 46×92×28.6mm                                 |

[Positioning: 3-in-1 version \(RS485 to 4G/RS485 to network port/network port to 4G\)](#)  
[Features: RTU performance at the price of a DTU](#)

[Positioning: 4G Ultimate version \(high-speed 4G cat 4 version\)](#)  
[Features: VPN transparent transmission, perfect support for remote debugging](#)

| TBox-4G/A   | TBox-4G/A-EU                       | EC-IC502-2-CN   | ICA400-06N                           | ICA400-26-EU                         | ICA400-26N-EU                                 | ICA400-26N-LA                                       | ICA100-06N-EU                          | ICA400-00HNPC   |
|---|------------------------------------|---|--------------------------------------|--------------------------------------|---|---|--|---|
| 11095-00038   | 11095-00037                        | 11095-00009   | 11095-00025                          | 11095-00039                          | 11095-00039                                   | 11095-00040   | 11095-00029                            | 34008-00160   |
| Elevator Industry Version   | Elevator Industry European Version | 4G Expansion Card for Inverter                                    | 4G Version for Photovoltaic Industry | 4G Version for Photovoltaic Industry | 4G European Version for Photovoltaic Industry | 4G Latin American Version for Photovoltaic Industry | WiFi Version for Photovoltaic Industry | Youth Version for Photovoltaic Water Pump Industry                |
| Comes with a 30MB/month voice data SIM card                                 | No SIM card                        | Comes with a 30MB/month data SIM card                             |                                      |                                      | No SIM card                                   |   | No need for a SIM card                 | No SIM card   |
| 4G<br>5Mbps   |                                    |   |                                      |                                      |   |   | WiFi (2.4GHz)<br>10Mbps                | 4G/3G/2G<br>5Mbps   |
| RS485/232/AUX/Type-c  |                                    | RS485/232   |                                      |                                      |   |   |  |   |
| 10Mbps  |                                    |   |                                      |                                      |   |   | 54Mbps                                 | 10Mbps  |
| IP20  |                                    | IP00  |                                      | IP65                                 |   |   |  | IP00  |
| DC 10~24V   |                                    |   |                                      | DC 5~12V                             |   |   |  | DC 10~24V   |
| 3W  |                                    |   |                                      | 3.5w                                 |   |   | 1.5w                                   | 2W  |
| Server Indicator, Network Status Indicator, Operation Status Indicator      |                                    |   |                                      |                                      |   |   |  |   |
| Standard Rail Mounting  |                                    | Screw   |                                      | Aviation Interface                   |   |   |  | Screw   |
| -25°C~65°C  |                                    |   |                                      |                                      |   |   |  |   |
| CN Version  | EU Version                         | CN Version, This Series Supports EU/LA Versions                   |                                      | Supports CN/EU Versions              | EU Version                                    | LA Version  | Supports CN/EU Versions                | CN Version  |
| External  |                                    | Internal  |                                      |                                      |   |   |  |   |
| Supported (Optional)  |                                    | Not Supported   |                                      | Supported                            |   |   |  | Not Supported   |
| Engineering Plastic   |                                    | No Shell  |                                      | Engineering Plastic                  |   |   |  | No Shell  |
| Supported   |                                    |   |                                      |                                      |   |   |  |   |
| Supported in Non-standard Cases   |                                    |   |                                      |                                      |   |   |  |   |
| Supports Inverter Upgrade (Elevator, GD270/350 Platform Dedicated Products) |                                    | Supports Inverter Upgrade (GD270/350 Platform Dedicated Products) |                                      | Supports Inverter Upgrade            |   |   |  | Supports Inverter Upgrade (GD270/350 Platform Dedicated Products) |
| Supported   |                                    |   |                                      | Not Supported                        |   |   |  | Supported   |
| Not Supported   |                                    |   |                                      |                                      |   |   |  |   |

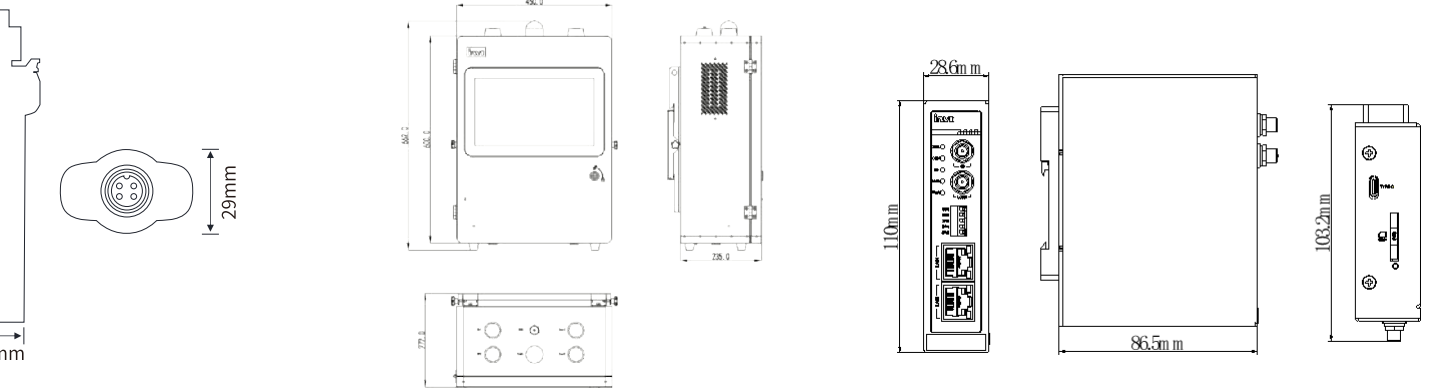

| W×H×D (including clips) | Weight (excluding antenna) |
|-------------------------|----------------------------|
| 29mm                    | 47g                        |

| Model                 | Dimensions (W×H×D) (including rail clips) | Weight (excluding antenna) |
|-----------------------|---|----------------------------|
| ICA-C Control Cabinet | 450×600×662mm                             | 28.6kg                     |

| Model               | Dimensions (W×H×D) (including rail clips) | Weight (excluding antenna) |
|---------------------|---|----------------------------|
| ICA-E Edge Terminal | 28.6×103.2×110mm                          | 0.65kg                     |

Small PLC

Medium PLC

X86 Controller

I/O System

HMI

Industrial Internet

## IWOCloud industrial cloud platform

INVT develops the industrial IoT data processing platform to provide a stable, safe, and high-efficiency base for various IoT industries and application scenarios. As the IoT "brain", the platform provides large-scale data terminal node access and high concurrent terminal access capability to accept, clean, arrange, distribute, and save data uploaded from various devices. In addition, it provides standard database interfaces in unified data format externally, meeting enterprise informationization development needs.

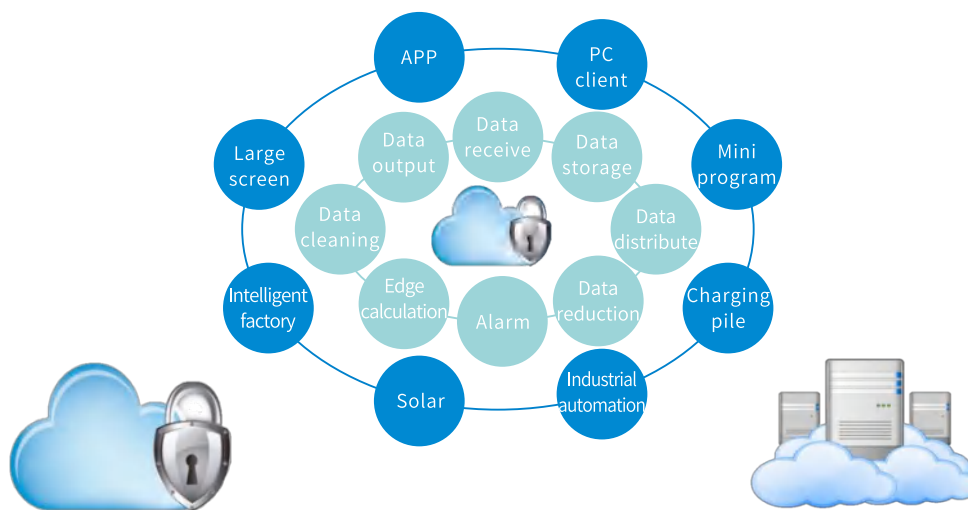

### INVT public cloud platform

Customers upload device acquired data to INVT cloud platform (IWOCloud)

- System running: safe and stable
- Maintenance: at low cost

### Privatized IoT platform

Customers can deploy industrial cloud platform with private permissions on specified servers, and upload device acquired data to the platform.

- Data privatization
- Maintenance: at high cost for the need of specialist for system stability maintenance



Small PLC  
Medium PLC  
X86 Controller  
I/O System  
HMI  
Industrial Internet

## Industrial cloud service



Policy file maintenance service

ICS-SW

Data acquiring policy  
File maintenance service



Data flow card service

ICS-SIM-

- Standard card: 30MB per month
- Large data flow card: 100MB per month
- Users can recharge their cards before the 12-month service life expires.



Cloud data storage service

ICS-DS-

- 6M: The data storage rolling period is 6 months.
- 12M: The data storage rolling period is 12 months.



Cloud platform use and maintenance

ICS-PF

INVT cloud platform use and maintenance

### Data flow card service

- Standard card: 30MB per month
- Large data flow card: 100MB per month. Users can recharge their cards before the 12-month service life expires

### API service

- CS-API: A third-party system can obtain device real-time data, facilitating remote device control and remote program upgrade.
- Standard version: The service application system provides data interfaces, for third-party systems to invoke data.
- Customized version: Data interfaces can be customized based on third-party system requirements.

### Policy file maintenance service

- ICS-SW: Data acquiring policy file maintenance service, implementing the upgrade or update on different data points of monitored devices

### Cloud platform use and maintenance

- INVT cloud platform use and maintenance

### Cloud data storage service

- 6M: The data storage rolling period is 6 months
- 12M: The data storage rolling period is 12 months

Air compressor IoT comprehensive service management platform

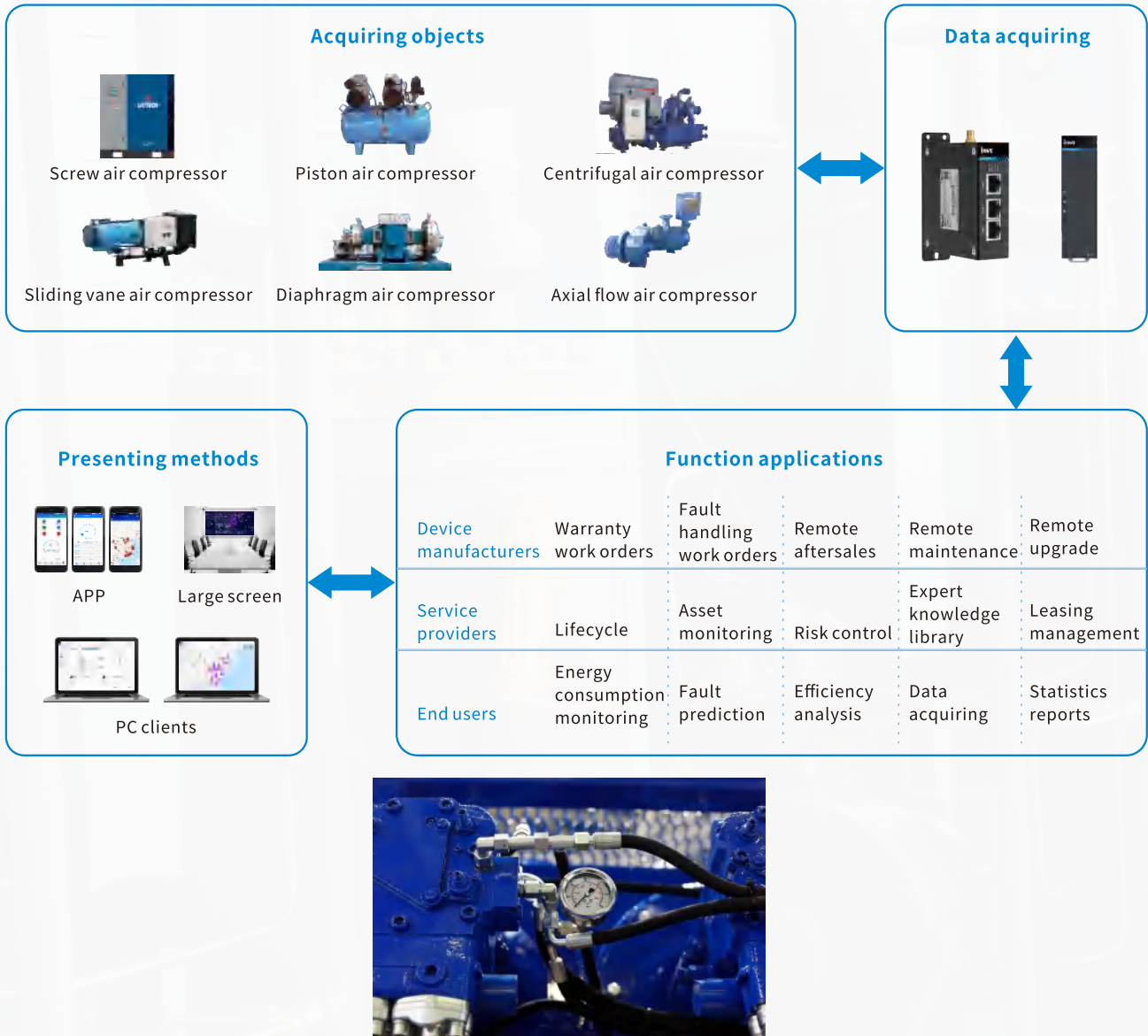

● Solutions

1. Saving aftersales costs: Remote aftersales can improve overall aftersales efficiency and reduce aftersales costs.
2. Device status monitoring and operation analysis: The best economic efficiency of replacing vulnerable and consumable parts can be achieved by real-time detection and intelligent analysis of these parts of air compressor.
3. IoT supervision and online leasing business: The ownership of leased device is separated from operational services, improving efficiency and reducing risks.
4. Refined energy consumption management: Through the IoT management, an enterprise can achieve a reduction of approximately 10% in energy consumption under the same operating conditions, saving at least RMB 700,000 in energy consumption costs annually.

## Multi-Device Joint Control System for Air Compressor Applications

By leveraging intelligent algorithms, the system optimizes air compressor operation to reduce energy consumption, enhance

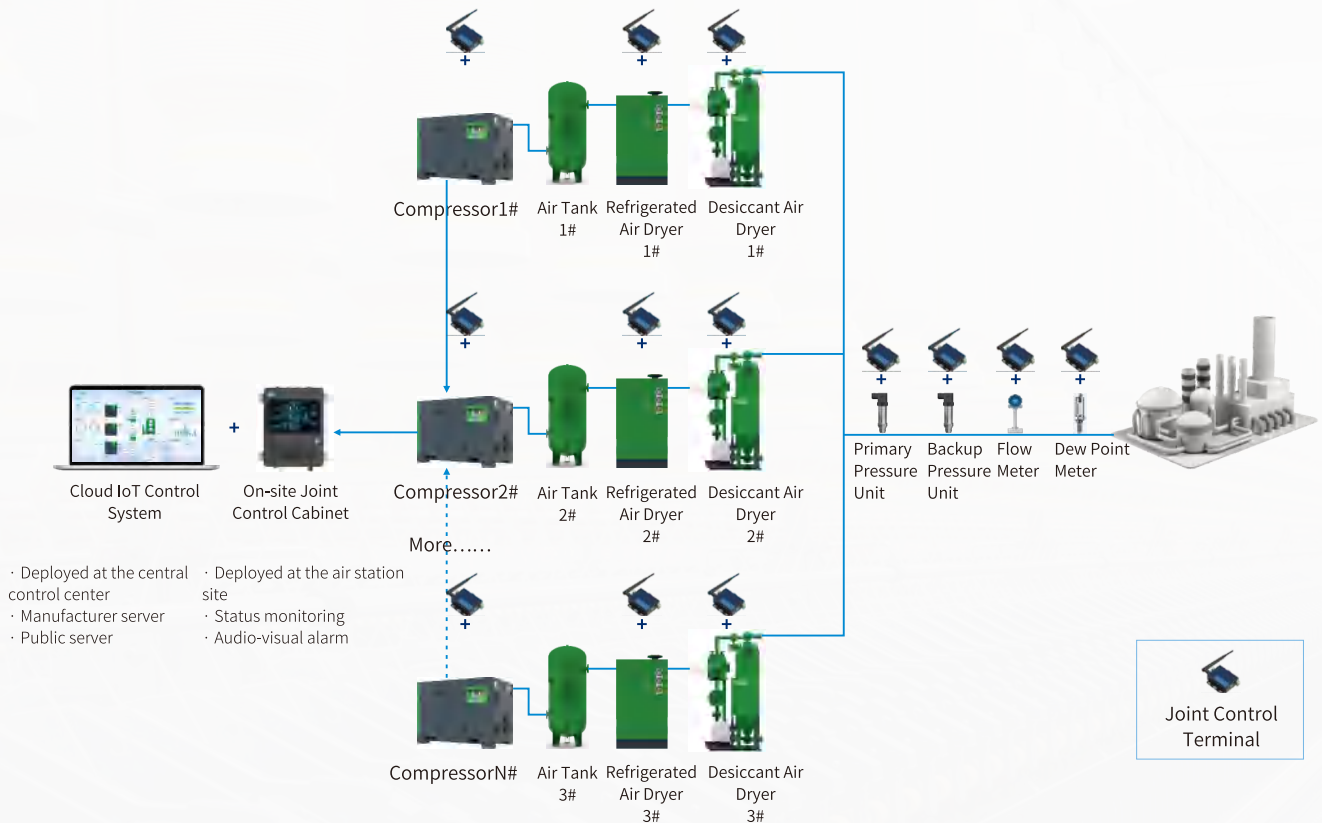

ICA Joint Control Cabinet

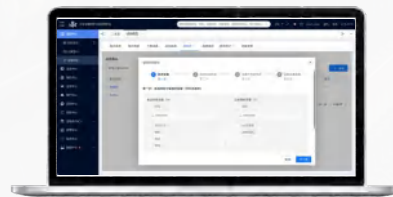

Algorithm Configuration

### Station-Wide Energy Saving

#### From single-unit optimization to system-level efficiency

Equipment utilization rate, specific energy consumption, cumulative power consumption, etc

#### From “Cruise Control” to “Autonomous Operation”

Using conditional algorithms, the system automatically adjusts loading and unloading based on actual equipment operating conditions to ensure continuous and efficient operation

#### Actual Effect of Single Pressure Band Operation

Reduces pressure difference between devices, maintains constant pressure, and minimizes ineffective energy consumption in workshops

#### Big Data Visualization Technology

Comprehensive analysis of system investment returns, energy efficiency, control records, and 9 major analysis categories

### Solution Value: Station-Wide Energy Saving

- 1.Reduce Idle Operation Waste:Balance air compressor operating time, switch equipment status in real time, and minimize idle running and unnecessary startup losses.
- 2.Lower Network Average Pressure:Multi-parameter control of main pipeline flow, main pipeline pressure, and terminal pressure reduces overall network pressure fluctuations.
- 3.Reduce Specific Energy Consumption:Through precise multi-parameter control (main pipeline flow, main and terminal pressure), network pressure fluctuations are minimized.Within the typical pressure range of 6–8 bar, every 1 bar reduction in discharge pressure can lower energy consumption by approximately 7%.

## Construction machinery IoT smart management platform

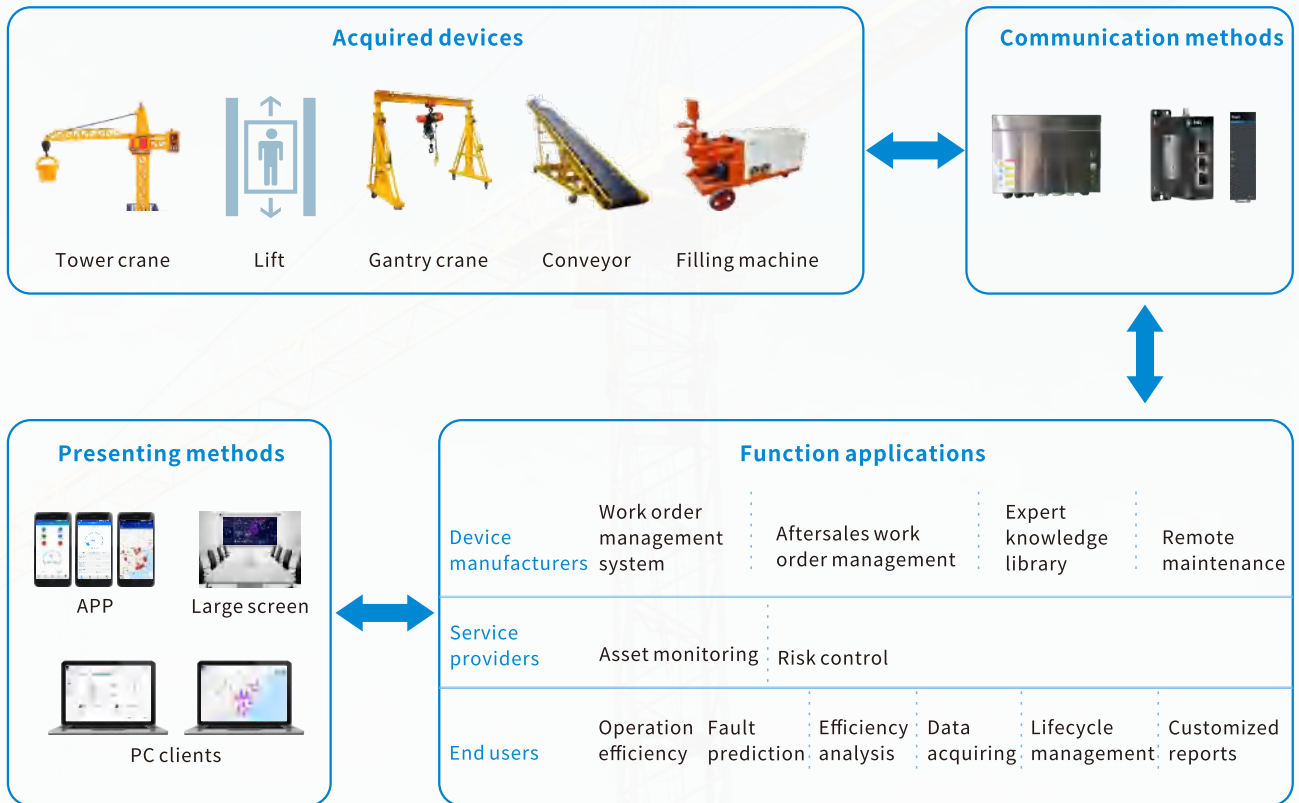

### ● Solution

#### Device manufacturers

1. Fault work order management: can handle faults timely and accurately, improving user experience.
2. Aftersales and maintenance work order management: can rigger maintenance tasks actively through remote aftersales and remote control, enhancing customer stickiness, and driving accessory sales.
3. Expert knowledge library management: precise fault handling suggestions pushing to assist in efficient management.

#### Service providers

1. Risk control: By combining IoT technology to achieve online leasing business, separating ownership of leased device from operational services, improving efficiency and controlling risks.
2. Timely reminder of payment: For device service providers' leasing business, a reminder of lease expiration can be provided to reduce repayment risks.

#### End users

1. Device monitoring: Real time monitoring of device status and implementation of over limit alarm mechanism for key parameters to ensure onsite safety production.
2. With the help of IoT terminal devices on construction sites, onsite inspectors can track device conditions and respond promptly to emergency situations.
3. Data report management: can generate health data for devices, facilitating maintenance operations, preventing faults, and timely notifying manufacturers for repairs.
4. Full lifecycle management of construction machinery: all device data is fully recorded for engineers to access.

PV water pump IoT smart management platform

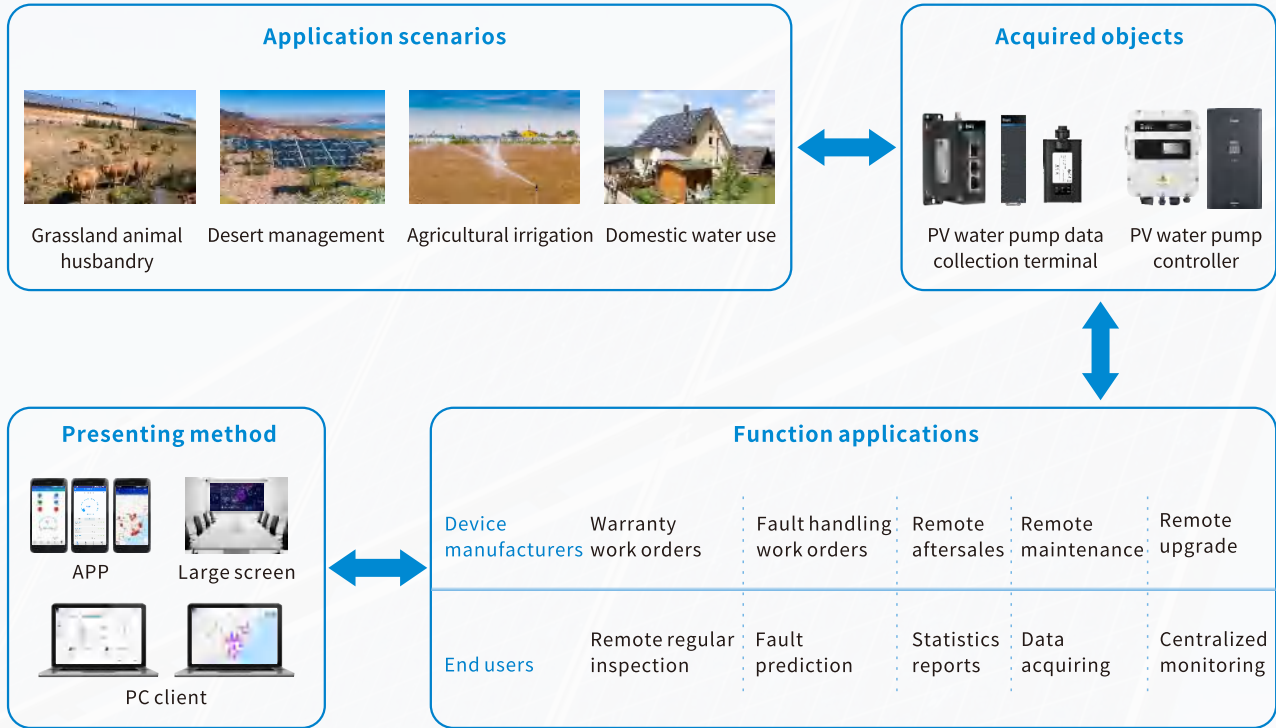

PV water pump IoT platform

● Solution

1. Smart regular inspection and efficient O&M: can realize remote monitoring and analysis of PV water pump faults and exceptions, effectively solving practical problems such as difficult monitoring and control of PV water pumps, inspection difficulty, and low O&M effectiveness. Ultimately, the annual cost of O&M and inspection can be reduced by 30%.
2. Panoramic monitoring: can acquire operational data information such as voltage, current, and power of PV water pumps in real time, comprehensively monitor the operation of PV devices, and make intelligent analysis to achieve maximum operational efficiency of the entire PV water pump system.
3. PV water pump devices can be remotely controlled through computers and mobile phones, and key parameters of the devices can be remotely regulated.

## Smart factory solution—Energy saving, emission reduction, production increase and efficiency enhancement

The smart factory solution is a full lifecycle management system for a digital factory or product from requirements to design, production, operation, and maintenance. The purpose is to summarize and integrate the manufacturing data, operation data, maintenance data, and then analyze and process the data through big data analysis systems and artificial intelligence systems, ultimately completing the optimization, production capacity improvement, efficient operation, remote pre-maintenance.

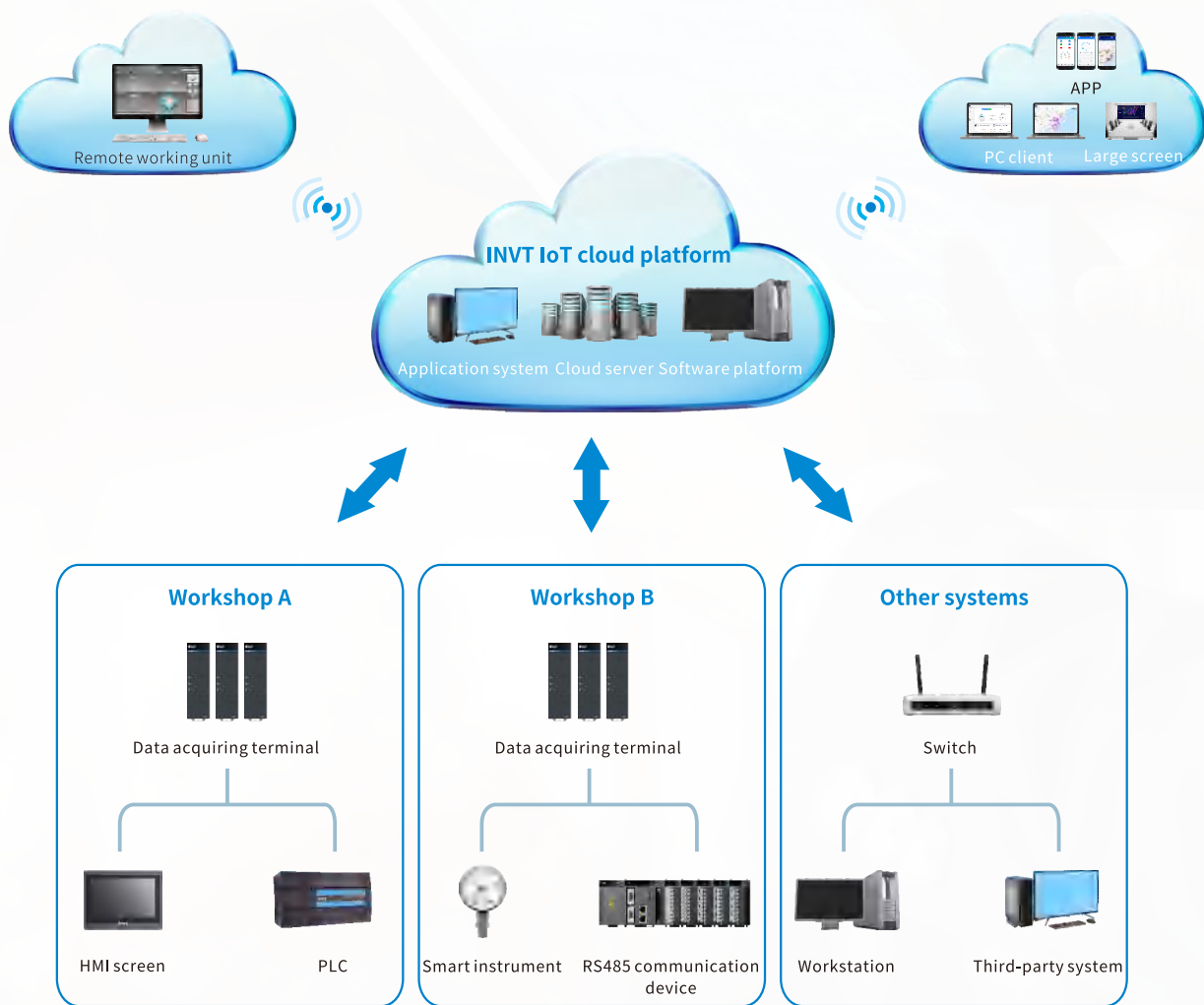

INVT IoT solution gradually achieves the goal of energy saving, emission reduction, and production increase and efficiency enhancement in smart factories in three stages:

1. To realize the interconnection and intercommunication of various industrial device data in the factory.
2. To manage factory device energy consumption and faults.
3. To establish a mathematical model for device energy saving, emission reduction, and production increase and efficiency enhancement by means of data analysis.

## IESM - Elevator IoT monitoring and management platform

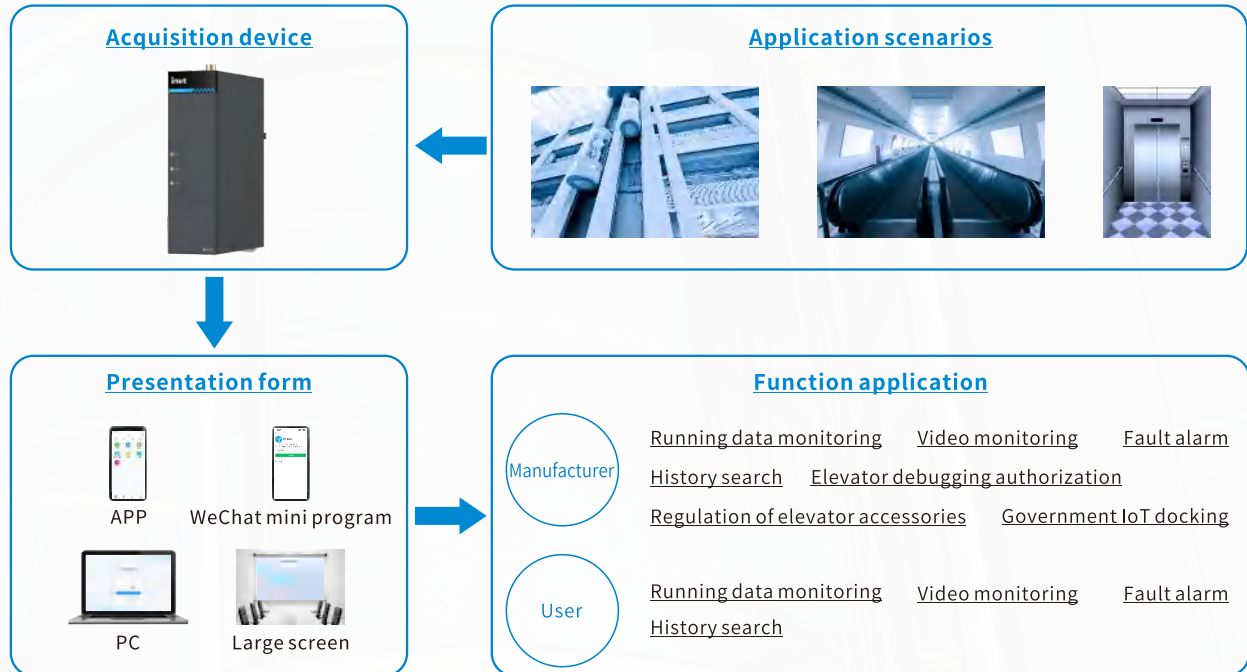

### ● Solution

1. Elevator debugging tools: The elevator main control and other auxiliary boards can be debugged through the APP, and the debugging permissions of the elevator can be supervised, so that only authorized personnel can perform elevator debugging.
2. "Digital housekeeper" of elevators: The accessories of elevators are supervised to ensure that only authorized elevator components can be installed for normal use, and avoid the use of illegal components that may affect the safety of elevator operation.
3. Real-time monitoring of operation status: Maintenance personnel can understand the health of the elevator at the first time, and take targeted measures.
4. Automatic push of faults and alarms: When a fault occurs, maintenance personnel will be notified in a timely manner through SMS. When a critical fault occurs (people trapped), the platform can automatically call the maintenance phone to timely appease the trapped personnel.
5. Data docking with government platforms: Currently, the docking work has been achieved in Shanghai, Hangzhou, Jiaxing, Jinhua, Ningbo, Shenyang, Fuzhou, Liaoning, Huzhou, Lishui and other places.

## Textile IoT smart management platform

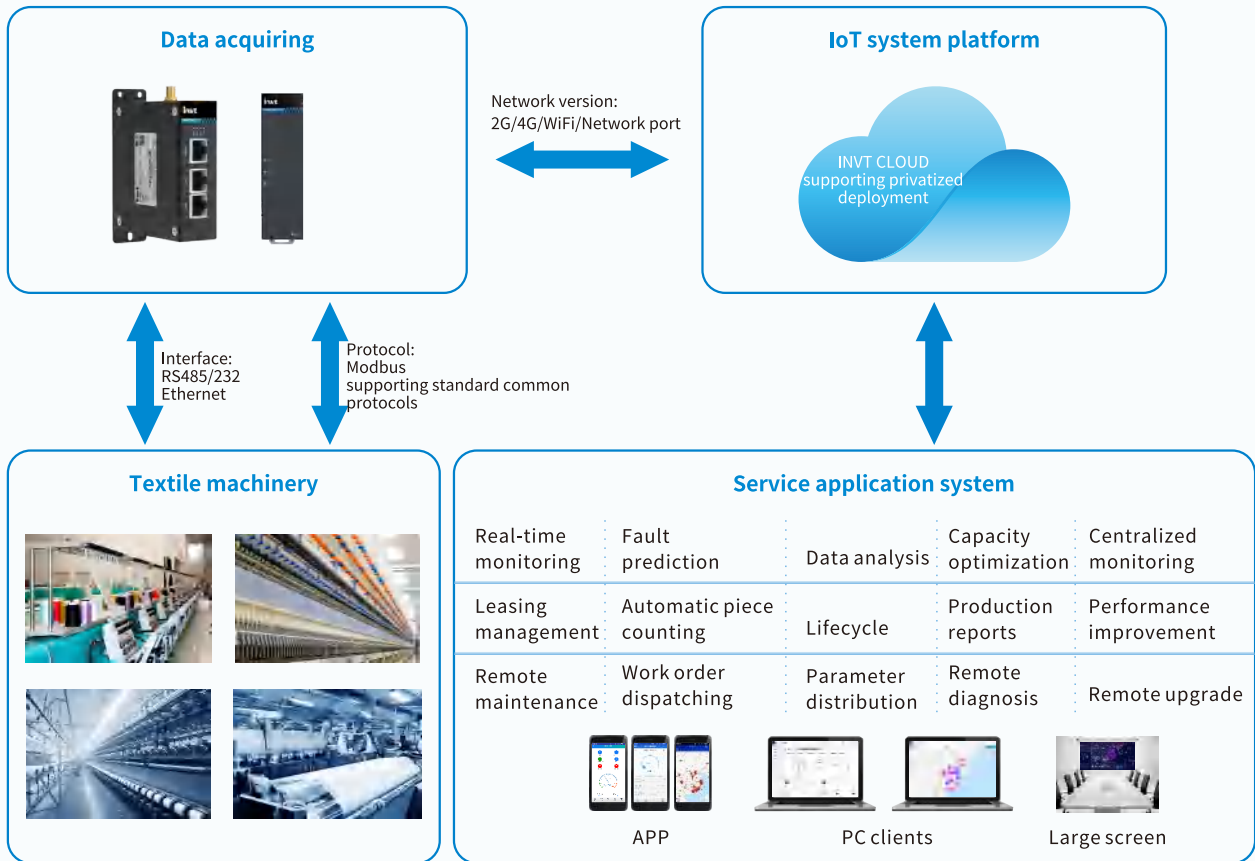

Textile process production line

### ● Solution

1. It realizes remote monitoring of textile production line device, batch parameter distribution, real-time monitoring of device status, improving production efficiency.
2. It realizes remote fault prediction, reducing downtime of textile production line device, ensuring system stability, and reminding of periodic device maintenance.
3. It realizes the integration of IoT platform with enterprise ERP, PLM, CRM, SCM and other management information systems, helping enterprises in efficient resource flow and integration from product design to production, and ensuring the stability and efficiency of production.

Аурум-Електро - більше 10 років  
офіційний імпортер та сервісний центр  
INVT Electric

**Номер телефону**

099-35-90-777

096-35-90-777

**E-mail**

shop@aurum-electro.com.ua



**Офіційна адреса сайту**  
[www.shop.aurum-electro.com.ua](http://www.shop.aurum-electro.com.ua)